

# Mortise and Tenon: A Primer

*Joining long grain to end grain with mortise and tenon — the king of rail joints*

By Ian Kirby

**A** mortise and tenon joint is nothing more than a square peg in a square hole. The joint is either stopped or through. The through joint is usually wedged, which makes it effectively a dovetail joint. Chances are there isn't a house in the U.S.A. that doesn't have examples of the joint somewhere in its furniture or built-in cabinets.

In this article I'll describe the three main ways the joint is used. Since the geometry of any design follows a certain set of conditions, it's vital to understand that aspect of the joint. I'll also explain how to design for strength.

In a subsequent article I'll put theory into practice by looking at ways the joint can be cut and describe, through the making of a simple table, what you must do before and after cutting the joint.

Although the basic joint is simple, its design details vary in complexity and sophistication according to the following circumstances: Do the two or three pieces being joined form the corner of a two-dimensional frame, as in a door, or a three-dimensional frame, as in a table? Or, do they form a T-shape, as in a center rail? And finally, is the joint through or stopped?

Over the years the mortise and tenon assumed a variety of design forms for a variety of reasons. I've illustrated some of them along with brief comments. Regardless of their design peculiarities, to work correctly each must follow the general design characteristics of the more common forms.

In many joinery situations where a mortise and tenon would have been the traditional solution, two recent alternatives have proved their worth and may be appropriate. They are plate joints and pocket screws inserted with the aid of oriented holes.

**Two-dimensional frames**  
(doors, mirrors, wall panels)



**Three-dimensional frames**  
(tables, chairs, beds)

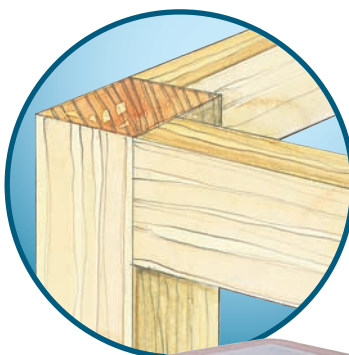

**Carcasses**  
(bookshelves, etc.)



Although these pieces of furniture were built by three different craftsmen and represent vastly differing styles, they share the mortise and tenon as their foundational joint.

## Defining the parts

A = Tenon length = Mortise depth  
 B = Tenon width = Mortise length  
 C = Tenon thickness = Mortise width

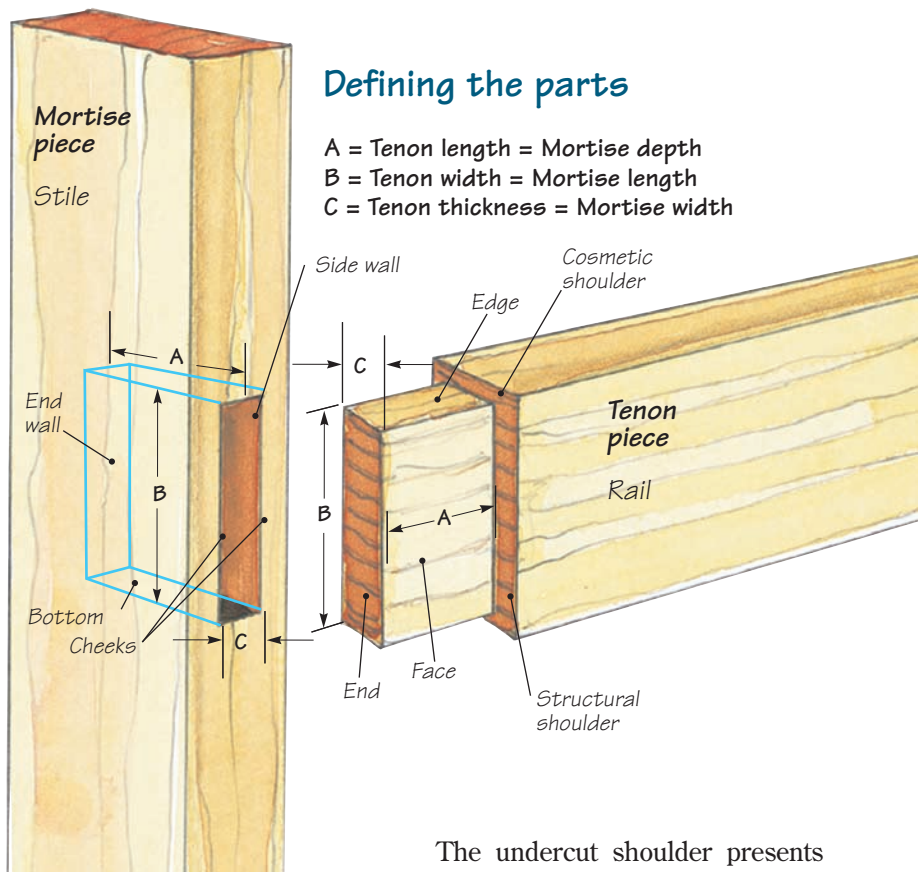

### Anatomy of Parts

A key step to understanding mortise and tenon joinery is knowing the parts, many of which are derived from human anatomy.

The specific name of the mortise/tenon piece depends upon its function and orientation. The mortise piece is usually the upright member, such as a stile, leg, or post. The tenon piece is usually horizontal, such as a rail, an apron, a stretcher, or a shelf.

### Dimensions of Parts

*A = Tenon length = Mortise depth*

On a stopped joint leave a gap between the end of the tenon and the bottom of the mortise. The two parts don't need to meet since the end grain of the tenon isn't a gluing surface, and it's easier to make if you leave a gap of about 1/16".

*B = Tenon width = Mortise length*

Make the tenon width to exact fit. If it's too narrow, the tenon may float and position the rail in the wrong place. For the same reason, don't crush the the edges of the tenon during assembly thinking you are making the joint tight. More likely you are causing misalignment. The end walls of the mortise are end grain and therefore not suitable gluing surfaces.

*C = Tenon thickness = Mortise width*

Make the tenon width to exact fit. If it's too thin, it will likely float and position the rail in the wrong place.

You should be able to "push fit" the parts together. A "clamp fit" with squeaky resistance is too tight. Applying glue will swell an easy-fit joint much tighter. A too-tight joint might split when glue is added.

### Geometry of Parts

Accurate joinery, whether cut by hand or machine, is defined by accurate geometry.

Some authors recommend undercutting the shoulder to ensure a tight-fitting joint. My view is — don't. First, what is undercut? 85°? 70°? Second, how do you measure it? Third, if you can undercut consistently, its stands to reason you can also cut square.

The undercut shoulder presents an edge to the stile instead of a flat face. Clamp pressure easily pushes the edge into the stile, distorts the wood, and changes the between-the-shoulders distance. Most important, you also lose the mechanical efficiency of a dead stop.

Mortise and tenon joinery is subjected to two types of stress. One type arises from use, as when we lean back in a chair or push a table to a new location. The other type arises from wood movement. Wood shrinks and expands across the grain in response to changing humidity but not along its length.

To cope with both types of stress, we design the joint to be as strong as possible. Since the configuration and section of the parts being joined are usually unique, we must design for the job at hand and that design is based on experience about what has worked before.

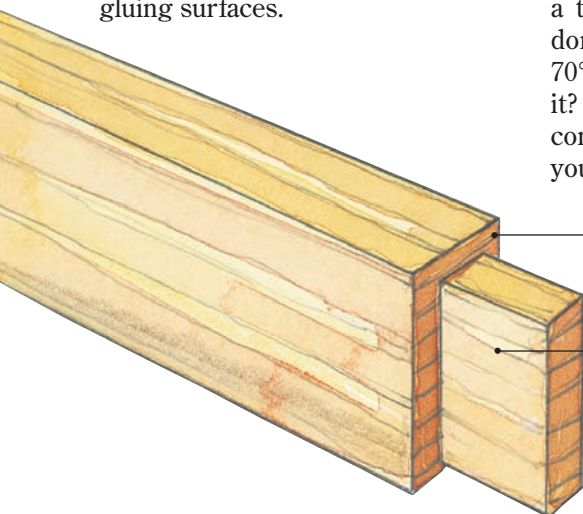

Shoulders square to face side and other faces

Faces aligned with stock, with no twist

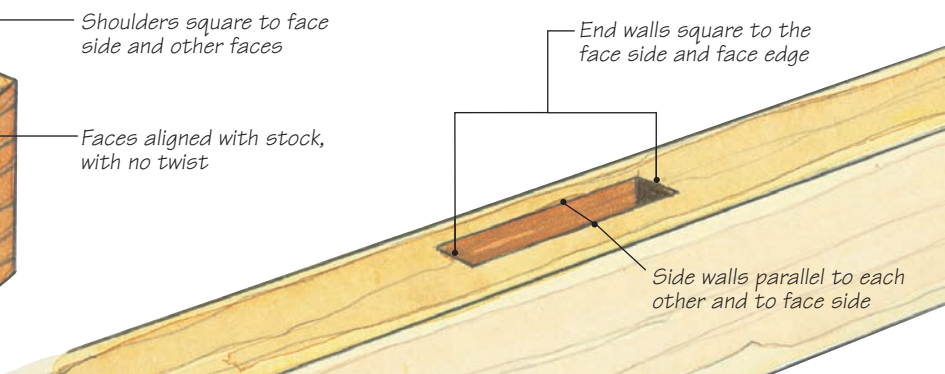

End walls square to the face side and face edge

Side walls parallel to each other and to face side

## Designing for strength

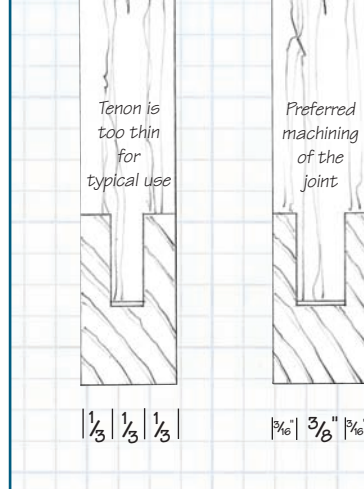

### MORTISE & TENON RULES

1. Hidden mortises should penetrate about halfway into a stile.
2. Create Balanced joints.
3. Structural shoulders resist stress.
4. Cosmetic shoulders hide the joint.
5. At the end of a stile, leave a horn. (to resist splitting)
6. Don't undercut.

When joining two pieces of the same thickness, balancing the joint for strength amounts to making the thickness of the two cheeks added together equal the thickness of the tenon.

### Shoulders

All tenons require shoulders. There are two types. Structural shoulders resist bending stress. Cosmetic shoulders hide the joint if the rail shrinks and they hide the gap presented by a damaged mortise end or a mortise made slightly long. Cosmetic shoulders need be only 1/8" to be effective.

A tenon without a shoulder on one side is called a barefaced mortise and tenon. To keep it aligned at the glue-and-clamp stage requires purpose-made clamping blocks. I don't recommend this configuration. If at all possible, reduce the thickness of the tenon to get a shoulder on each side.

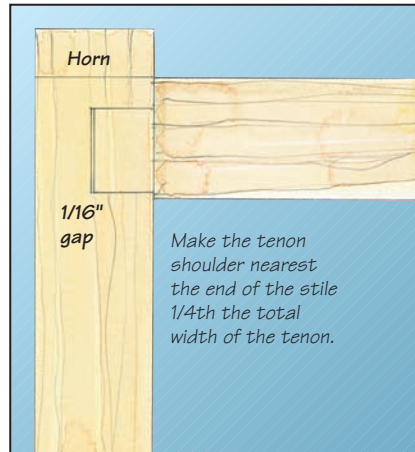

When a mortise is placed near the end of a stile, an extra inch or so of material is left to extend past the joint. This horn will be cut off later.

### Tenon Width, Mortise Length

If a mortise extends too near to the end of the stile of a corner joint (often, exactly the spot where you simply need a joint to go), the stile may split. Therefore, make the tenon shoulder nearest the end of the stile one-quarter the total width of the tenon. To keep from splitting the mortise, an extra inch or so (called the horn) is left on the stile. Once the glue is cured and the job is out of clamps, the horn is sawn off.

When the mortise is not at the end of the stile, make the tenon the full width of the rail, less 1/8" at each edge for the cosmetic shoulder.

### Tenon Thickness, Mortise Width

When joining two pieces of wood of the same thickness, divide the thickness roughly in half to create a balanced joint. For example, if the wood is 3/4" thick, make the tenon 3/8" thick and each mortise cheek 3/16" thick. Since each piece has an equal amount of tissue, each is equally able to resist stress and the joint is balanced.

### Loose-tenon Joint

A slot mortiser is a machine that cuts a mortise into both rail and stile. The two parts are connected with a third piece made to fit the slot, much like a biscuit joiner. This joint is called a loose mortise and tenon. You can make the joint using a plunge router and a single bit, although you will normally need different jigs to manage the two parts. Once glued, the joint is just as strong as a conventional mortise and tenon.

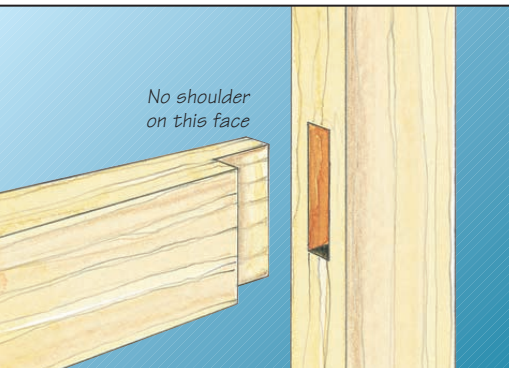

A tenon without a shoulder on one face of the stock, called a barefaced mortise and tenon, is not recommended. Try reducing the tenon thickness to get a shoulder on the bare side.

### Tenon Length, Mortise Depth

If the tenon is too long, the joint is under greater stress due to wood movement. Too short, and it may fail due to too little glue surface. My compromise is to mortise about halfway into the stile. In narrow stock, go a bit more than halfway.

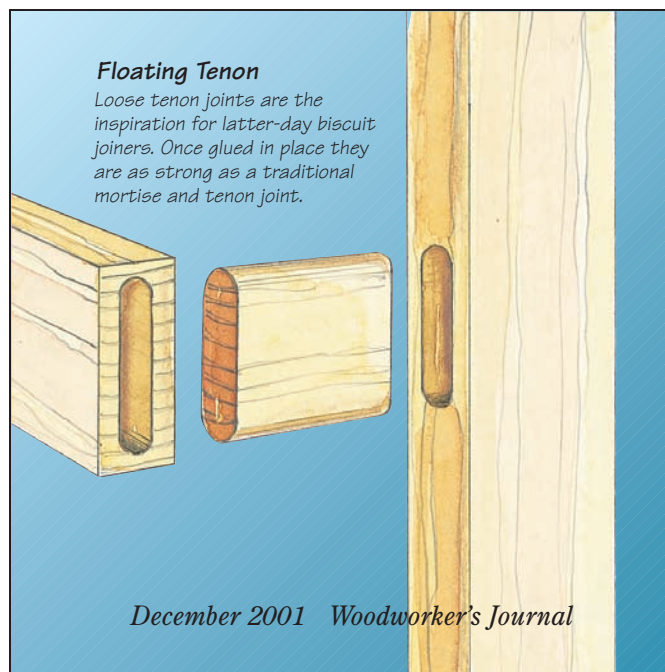

## Two-dimensional frames



A stile turned 90° to the rail provides the greatest resistance to stress. Typically the through tenon in that situation will be 1/4th the width of the rail.

### MORTISE & TENON RULES

7. The completed joint should slide together with moderate hand pressure.
8. Accurate geometry is the key to effective joinery.
9. With stopped tenons, always cut them 1/16" short of the end wall.
10. Use a sufficient amount of glue on the joints (but avoid over gluing.)



By slightly offsetting the through tenon, you can reduce your chances of splitting the stile and add stability to the joint.

### Frame and Panel

Two-dimensional frames with a solid panel trapped in a groove make a classic frame and panel. This ingenious construction is not only the foundation of furniture making, it remains the only method we have for making a dimensionally stable frame from dimensionally unstable solid wood. The traditional example is, of course, the frame and panel door. Although with modern material this door is no longer the most efficient design available, tradition and a sense of history continue to drive the popularity of this beautiful cabinet staple. Used in multiples, we can make larger frames, which, joined at the corners, make storage chests and cabinets.

A middle rail

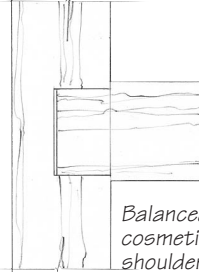

Balanced cosmetic shoulders

A top rail



Shoulder is offset from top of joint to avoid splitting.

Mortise and tenons and the flat panels easily created by them have long been the building blocks of solid wood construction. Adjust the position of the tenon at the end of the rail to logically suit the location of the rail in the panel.

## Mortise & Tenon Variations

Nearly as soon as there were woodworkers, the mortise and tenon joint was created — an efficient and elegant way to join solid wood. Variety being the spice of life and the essence of creativity, many kinds of mortise and tenon joints became common. Due to advances in machinery, adhesives, and techniques, the mortise and tenon variations illustrated here are seldom used today.

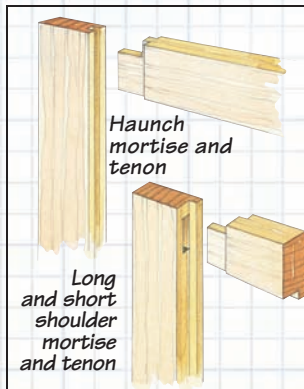

Haunch mortise and tenon

Long and short shoulder mortise and tenon

In the days of hand tool woodworking, grooves were made using a plow plane. Because you can't make a stopped groove with a plow plane, the haunch was left on the tenon to fill the groove. If the frame was to be fitted with a glass panel sitting in a rabbet, then the long and short joint was used.

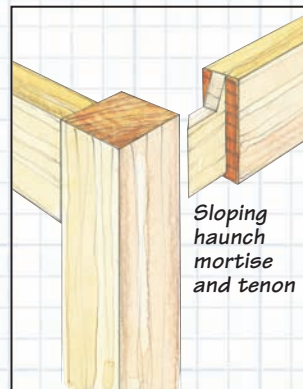

Sloping haunch mortise and tenon

On a three-dimensional frame, there is no need for a groove. The notion of a haunch, however, remained. A sloping haunch satisfies the psychological need for a haunch and the visual need for a flush shoulder line at the top edge.

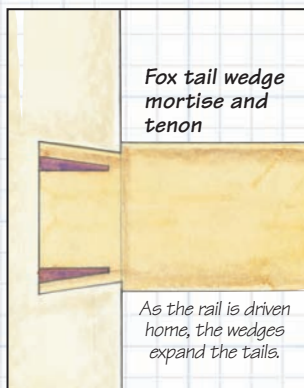

Fox tail wedge mortise and tenon

As the rail is driven home, the wedges expand the tails.

The author has made many fox tail joints but never used one in furniture! You only get one shot at glue-up. It's a clever concept, but there's no place in furniture where it's really necessary.

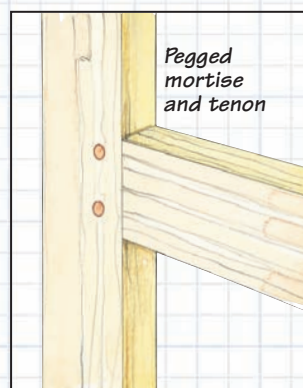

Pegged mortise and tenon

Draw pegging is a technique derived from timber frame construction. It's unnecessary with modern glues and correctly made joints, but if you like the look, add the pegs after the joint is made.

## Three-dimensional frames



Tables, chairs and other pieces of furniture are created from mortise and tenon joints constructed in three dimensions.

Three-dimensional frames are used to make table bases, chairs, and the skeletons of large cases. Three members generally connect, for example, a table leg and two rails or aprons. In most situations the vertical leg is more or less square in section, while the incoming rails are flat. Factors affecting the design of the joint include the width and thickness of the rails, the exact location of the rails on the faces of the leg, and complications caused by drawers or doors.

**Underframes** impart stability to a piece of furniture. On this one the design not only includes twin tenons, but wedged tenons as well.

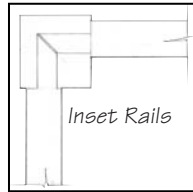
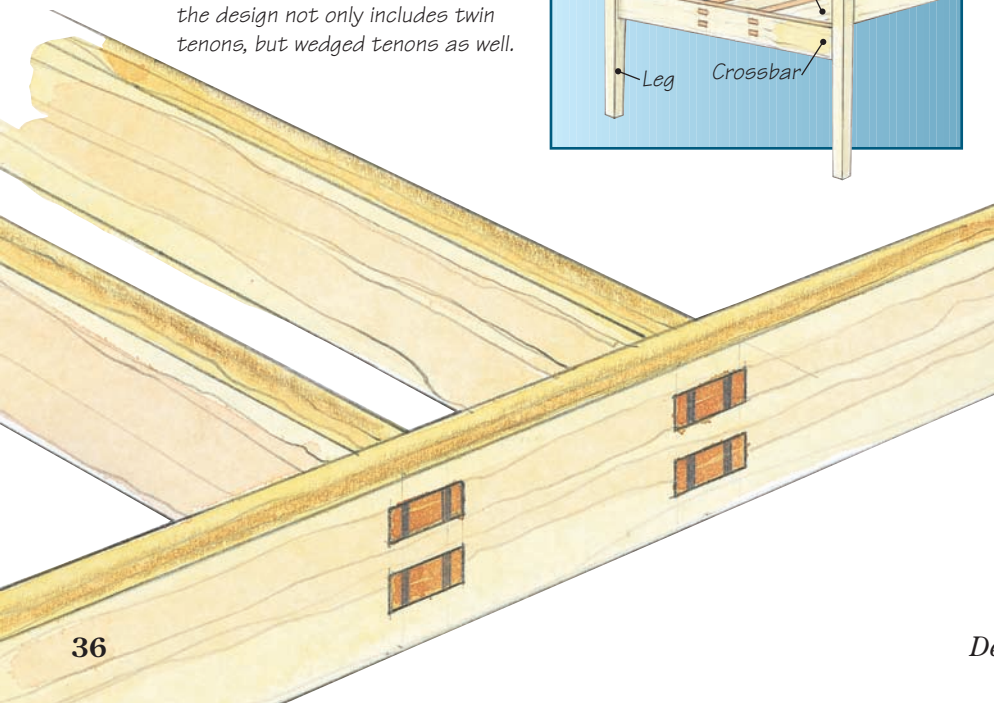

Inset Rails

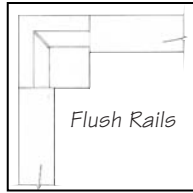

Flush Rails

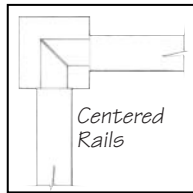

Centered Rails

**With three dimensional frame construction, design considerations become almost infinitely variable. Regardless of how the joint is employed to create a pleasing appearance, the rules of mortise and tenon joinery must be observed.**

The illustrations above show the rail in three different places on the leg. Once the joint is glued, the “flush rail” must be made dead flush by planing — a manufacturing detail unnecessary with the inset rail. However, the strongest reason to inset the rail is visual: the change in level, along with the associated highlights and shadows, emphasizes the vertical element of the leg.

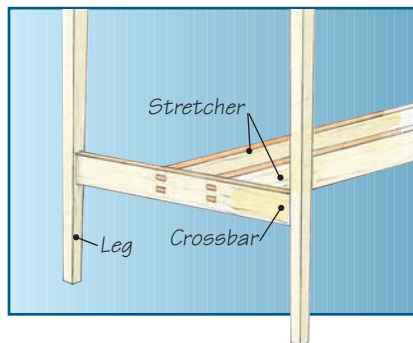

Note that the thickness of the tenon is increased as it is inset while the gluing area decreases. In each case the tenon is mitered in the middle of the joint. Provided the tenons don't touch, you can make the gap as small as you like. The 1/8" inside shoulder on the flush and inset rail is enough to do the job.

### Underframes

Underframes impart stability to a piece of furniture by bracing the structure. They often do double duty as supports for shelves.

Where two underframe members meet at a T-shaped junction, you can increase the gluing area by using twin tenons. If the joint is made through and wedged, it offers an attractive design detail.

### Twin Tenons

When the rail is thicker than 1", you can increase the gluing area by making twin tenons side by side. The total thickness of the two tenons is about the same as for a single tenon, but the doubled gluing area makes for a potentially stronger joint. The figure below shows typical proportions: the minimum thickness of each tenon is about 3/16", and the space between should be about equal the tenon thickness. Twin tenons are often used this way in chair making where a back rail joins a legs.

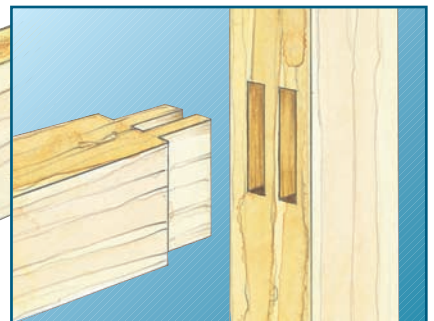

**Thicker stock offers the possibility of creating twin tenons. The key advantage to this modification is you nearly double the glue area.**

Short twin tenons also occur in carcass sides, where a partition ties the case together and also acts as a shelf. Make the housing (also known as a dado) about 1/8" deep between the mortises. A housing between tenons not only makes the shelf able to bear a heavy load, but it also flattens any cup in the two boards. Because the tenons would otherwise be very short, they are usually made through and wedged. Because of the 1/8" deep housing, a 1/2" thick tenon is plenty big.

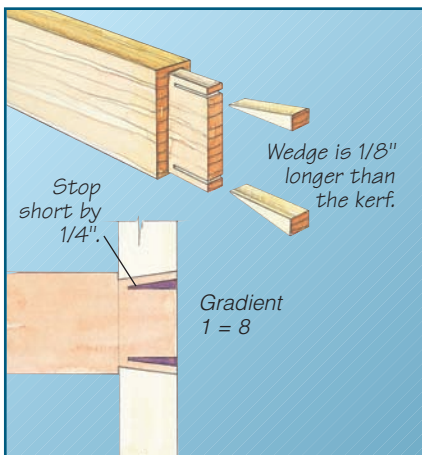

**A through-wedged mortise and tenon demands precision joinery. The wedge must thrust the stock against the end grain of the mortise. Place it the other way and you'll split the wood.**

### Gluing and Clamping

A simple yet elegant idea like the mortise and tenon joint can go wrong at the last moment. In a later article, I'll go through the basics of gluing and clamping. But for now I must simply say that incorrectly applied clamps and their critically important clamping blocks, or cauls, will ruin the best crafted joints in short order. So do not give short shrift to this last step in making a joint.

With these few concepts in mind, it's time to go to your shop and join some wood. Good cutting!



## Carcasses

One place where through mortise and tenons, and particularly twin tenons, occur regularly is in projects such as a bookcase. The through tenons are both structurally integral and visually beautiful. An additional joinery technique that the author regularly employs is a conjoined housing (or a dado here in America). The 1/8" deep dado shown between the mortises increases the weight-bearing capabilities of the shelf and flattens any cupping in the shelf and upright pieces. It also presents a clean and subtle joint line.

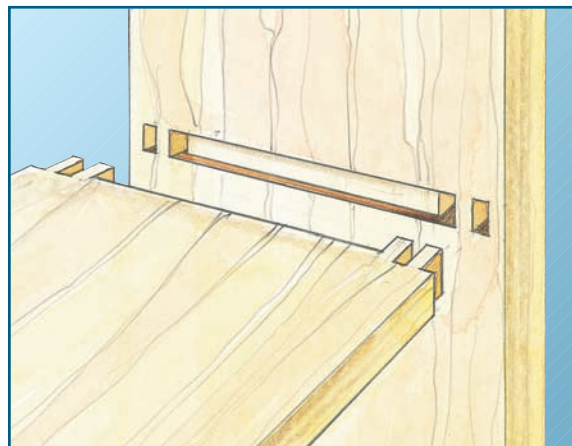
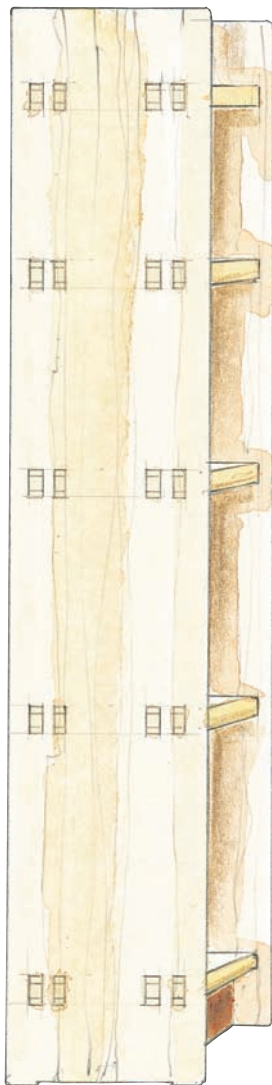

**In this example, the author recommends a shallow dado stretching between the through mortises.**

### MORTISE & TENON RULES

11. Don't think you can make accurate mortises by drilling the waste away and "cleaning up" with a chisel. If you don't form your mortises entirely by hand, try these easy to follow steps.

#### Ian's recommended process:

- a. After marking the joint, use an appropriate drill bit to carefully remove most of the waste.
- b. Use a plunge router and a router jig to further machine the mortise. This will give you parallel walls square to your work piece.
- c. Pare the corners square and true with a sharp chisel.

