

WOODWORKER'S JOURNAL

downloadable plans:
"America's leading woodworking authority"™

In this plan you will be getting:

- Step by Step construction instruction.
- A complete bill of materials.
- Exploded view and elevation drawings.
- How-to photos with instructive captions.
- Tips to help you complete the project and become a better woodworker.



To download these plans, you will need **Adobe Reader** installed on your computer. If you want to get a free copy, you can get it at: **Adobe Reader**.

Having trouble downloading the plans?

- If you're using Microsoft Internet Explorer, right click on the download link and select "Save Target As" to download to your local drive.
- If you're using Netscape, right click on the download link and select "Save Link As" to download to your local drive.

WOODWORKER'S JOURNAL
©2007 ALL RIGHTS RESERVED

Build a Bed Designed for Readers



Published in Woodworker's Journal "The Home Woodworker: Classic Projects for Your Shop and Home"

\$7.95

WJ070



Build a Bed Designed for Readers

This queen-sized bed features a perfectly inclined backrest, three large storage compartments and three drawers for your bedside collectibles. The crowning touch: Open the middle drawer and drop the support down to make a rock-solid resting place for that steaming mug of tea.

There's an old adage that says, "The longer your years, the shorter your days." Whether you consider yourself over the hill or not, life just seems to get busier as the years pass. If the only quiet time you have to catch up on reading is late at night when the kids are asleep, you'll love this project.

Most beds are designed for lying down, not sitting up and reading. Plus, few styles offer convenient storage for all the catalogs, books and magazines you may need to get through. Even bedside tables offer limited storage space for reading material.

This multiple-use queen-sized bed addresses a number of these problems. It features comfortable back support for reading and lots of storage. One key feature is the flip-down doors that are supported by the pull-out drawers. The backs of the doors then become small, but sturdy tables to hold books, popcorn bowls or maybe even a remote control if you surf the channels instead of read yourself to sleep.

Simple Headboard Cabinet Design

The headboard is essentially just a plywood cabinet with nine separate compartments. This subassembly is secured between two legs and topped off with a gently curved pediment made of walnut and ash.

Begin building the cabinet by cutting the sides, dividers, top, bottom and shelves (pieces 1 through 6) to size. You'll want to check the *Exploded Views* and *Elevation Drawings* throughout this article for the construction details. As this is hardwood veneered plywood, make the straight cuts with a fine-toothed plywood blade on the table saw to minimize splintering the veneer. Keep the best-looking side of each panel facing up as you cut: the tearout will occur when the blade exits the workpiece. Grab your router and straight bit to plow three 3/16"-deep dados across each side and

four across each divider (two on each side), as shown in the *photo* below. As the *drawings* show, these are all through cuts. Once they're made, adjust the bit depth to 1/4" to create stopped rabbets along the back edge of each side and the top, to accommodate the back. With the routing completed, lay out the angled front edges of the sides and dividers. Trim the angled cuts close to your line with a jigsaw, then clamp on a straightedge and clean up the edges with a 3/4" straight bit chucked in your portable router, as shown in the *photos* on the next page.

Dry-fit the cabinet together, then mill enough cap stock (piece 7) to trim the front edges of all the cabinet parts. This is just square stock, ripped and planed to size.

Assemble the cabinet with glue and clamps, making sure that it's flat and square.



The dados for the headboard's straightforward joinery are plowed while the sides and dividers are still rectangular. The angled front edges are laid out and cut next.



Get close to the layout lines for the side with a hand-held jig-saw. Then finish the cut with a router and a straightedge jig, (left), to smooth the saw marks.

Use a straightedge jig and a router with a straight bit to trim the angled front edges smooth and straight.

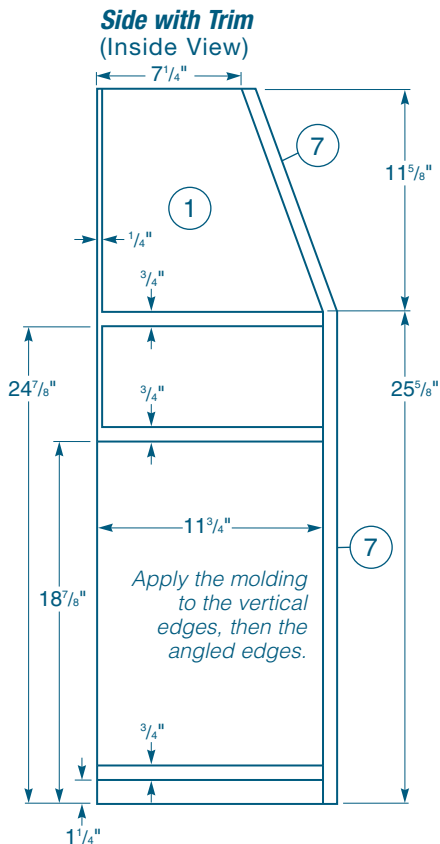

When the glue is dry, miter the cap stock to fit and apply it to the cabinet with glue and finish nails. Be sure to install the vertical strips first. Pre-drill pilot holes in the hardwood for the nails, and set the nail heads below the surface. The last trim to apply is the upper shelf trim (piece 8), which helps frame the drawer openings. Cover the holes with matching filler and sand it smooth after it dries. The plywood back (piece 9) and the lower panels (pieces 10 and 11) close up the headboard. Attach panel cleats (piece 12), setting them $\frac{7}{8}''$ in from the front of the headboard, and secure the panels with glue and screws. Fit the back into its rabbet and attach with brads.

Laminated Legs

The two headboard legs are created by laminating pieces of ash lumber to a $\frac{1}{2}''$ -thick walnut core. Face-glue and clamp one long ash lamination (piece 13) to each of the walnut

laminations (pieces 14). After the glue dries, clamp the two short ash laminations (pieces 15 and 16) to the other side of the leg and clamp them in place.

When dry, run each assembled leg across the jointer. Later, you'll need to form gentle curves onto the top of each leg to mate them to the arched pediments.



Glue the leg laminations together, holding the parts with plenty of clamps until the glue sets. Check the joint initially to remedy any glue creeping.

Graceful Arched Pediment

The curved top of the headboard and the footboard (the pediments) are built up with a series of five 3/8"-thick ash laminations (pieces 17) that are glued together in a plywood form. A sixth walnut lamination (pieces 18) will be installed after the pediments are secured to the legs.

A bending form forces each lamination into an arched shape and holds them all tightly together while the glue dries. After you rip and crosscut all 12 laminations to size, refer to the *sidebar* (at right) and the *Elevation Drawings* for directions on building your form. Then apply a liberal amount of adhesive between five of the ash laminations and clamp them in place securely.

When the adhesive is dry, scrape off the excess and pass one edge of the pediment across the jointer. Set your table saw fence so it's 6 5/16" from a sharp ripping blade and rip the pediment to width. (You may need a helper for this task — the pediment is a handful.) Then pass the ripped edge across the jointer, reducing the part to its final 6 1/4" width. Crosscut it to 68 1/2" long (measuring along the curve), then chamfer the bottom edge with a 45° bearing-guided chamfering bit. Run the bearing along the bottom face of the pediment so the router can ride the jointed sides (rather than having to follow the curve). Using several passes, shape the ends first, then the sides; this will eliminate any tearout from cutting across the grain on the ends. Before moving on, repeat this process to create the footboard pediment—it's identical to the headboard pediment.

Now clamp the legs temporarily in place on the headboard. Center one of the pediments on the two legs and trace its curve onto the face of the legs. Remove the legs and step to the band saw to cut the ends of each leg to the curved layout lines. Sand the curves smooth and exactly to the lines on a stationary disk sander. When the curves on the pediment and leg are a perfect match, glue and clamp the legs in place on the headboard.

CURVED LAMINATIONS

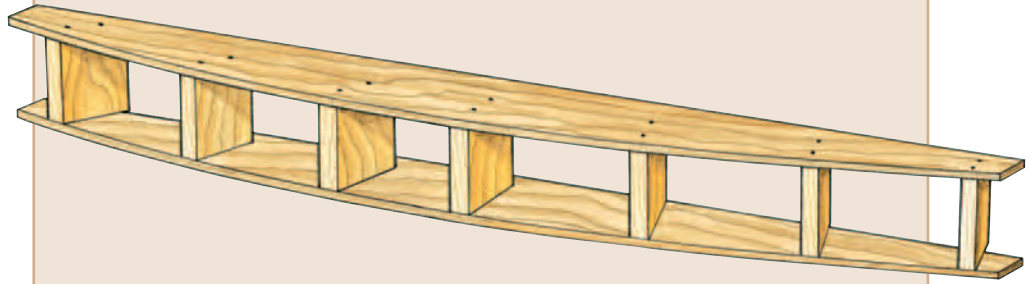

The arched pediments on the foot of the bed are created by gluing hardwood laminations together while clamped to a curved form. Make the form from plywood shaped and mounted to dimension lumber with glue and screws. It is important that the form's curve be fair and true. To form the curve on your jig, mark the endpoints and centerpoint and flex a thin strip of hardboard to lay out the shape. Use a belt sander to smooth out the long gentle arc. The form also needs to provide good purchase for the many clamps it takes to apply even pressure to this pediment build-up. If you're limited to using shorter clamps, make some clamp cutouts, as shown in the *Elevation Drawing* on the next page.

The type of adhesive to use is a significant consideration for this task. White or yellow woodworking glues may work, but their elasticity could allow the curve to creep and change shape, even after the glue cures. Epoxy is a better choice for this operation — specifically a mixture with a long open time. The open time not only provides enough time to place the laminations around the form and clamp them properly, but it also allows the resin to infiltrate the wood fibers, thus creating a stronger bond. If epoxy isn't a reasonable option for you, polyurethane glue is another good choice for dry-bent laminations.



Use epoxy or polyurethane glues for dry-bent laminations like this one. Yellow or white glues are not recommended.

Headboard Exploded View

Pediment Jig
(Top View)

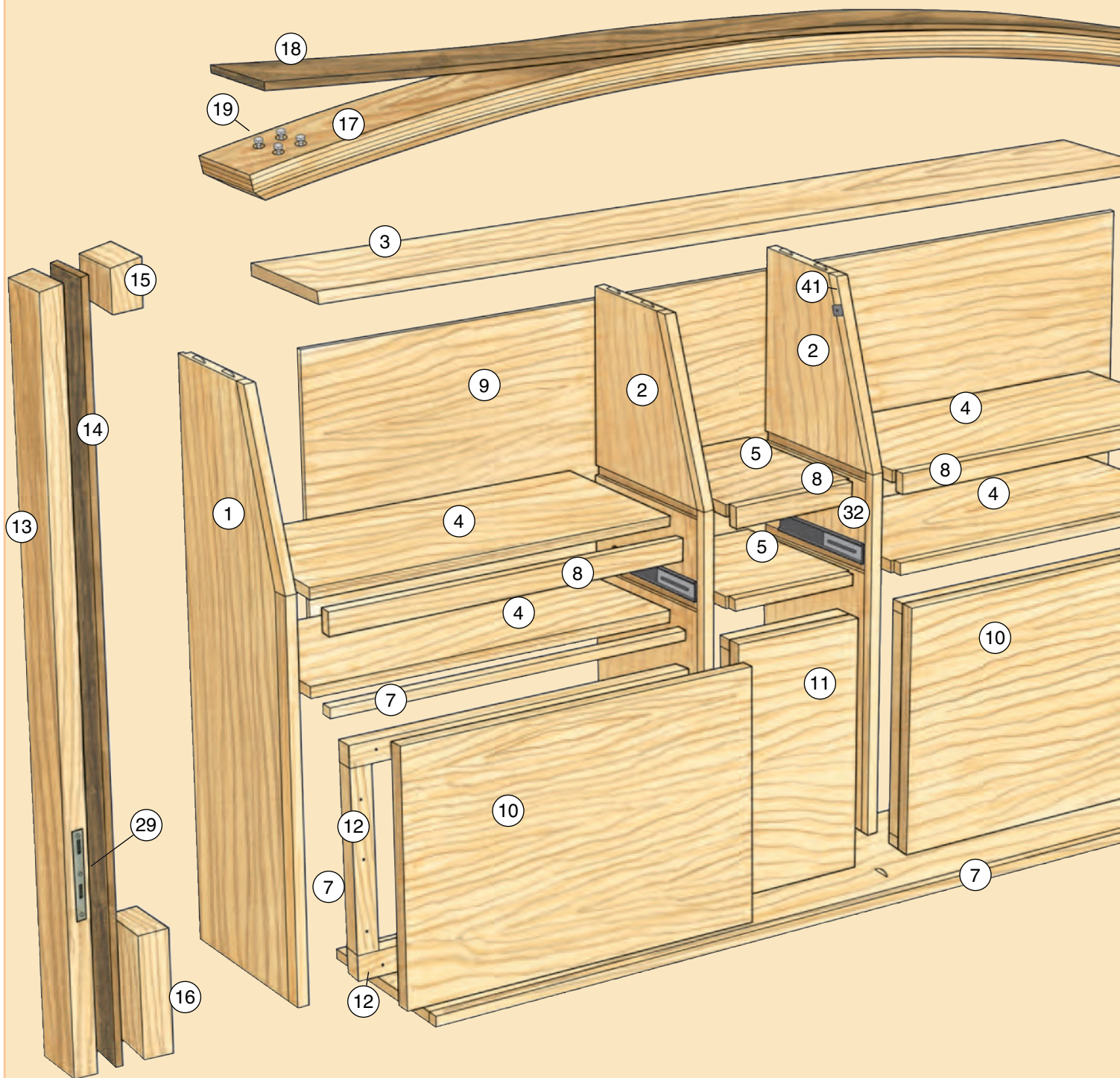
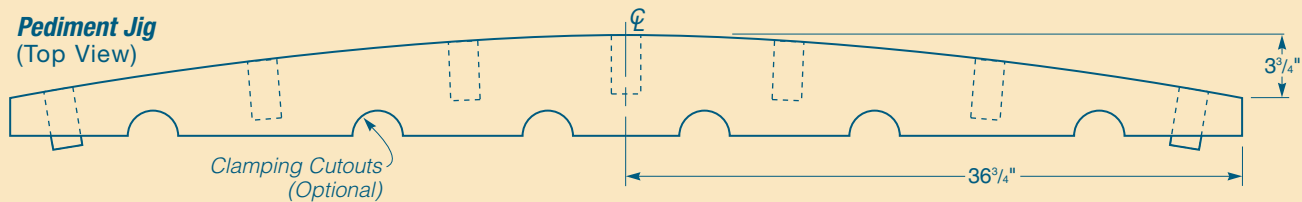

MATERIAL LIST—HEADBOARD

		T x W x L
1	Cabinet Sides (2)	$\frac{3}{4}$ " x $11\frac{3}{4}$ " x $37\frac{1}{4}$ "
2	Cabinet Dividers (2)	$\frac{3}{4}$ " x $11\frac{1}{2}$ " x $35\frac{1}{4}$ "
3	Cabinet Top (1)	$\frac{3}{4}$ " x $8\frac{1}{4}$ " x $61\frac{1}{4}$ "
4	Cabinet Large Shelves (4)	$\frac{3}{4}$ " x $11\frac{1}{2}$ " x 25 "
5	Small Shelves (2)	$\frac{3}{4}$ " x $11\frac{1}{2}$ " x $9\frac{3}{8}$ "
6	Cabinet Bottom (1)	$\frac{3}{4}$ " x $11\frac{3}{4}$ " x $60\frac{7}{8}$ "
7	Cap Stock Molding (1)	$\frac{3}{4}$ " x $\frac{3}{4}$ " x 350 "
8	Upper Shelf Trim (1)	$\frac{3}{4}$ " x $1\frac{3}{4}$ " x 60 "
9	Cabinet Back (1)	$\frac{3}{4}$ " x $18\frac{7}{8}$ " x $60\frac{3}{4}$ "
10	Large Lower Panels (2)	$\frac{3}{4}$ " x $16\frac{7}{8}$ " x $60\frac{5}{8}$ "
11	Small Lower Panel (1)	$\frac{3}{4}$ " x $16\frac{7}{8}$ " x 9 "
12	Panel Cleating (1)	$\frac{3}{4}$ " x $1\frac{1}{2}$ " x 210 "
13	Long Leg Outside Laminations (2)	$1\frac{3}{4}$ " x 4 " x $48\frac{3}{4}$ "
14	Long Leg Center Laminations (2)	$\frac{1}{2}$ " x 4 " x $48\frac{3}{4}$ "
15	Upper Long Leg Inside Laminations (2)	$2\frac{3}{4}$ " x 4 " x $2\frac{3}{4}$ "
16	Lower Long Leg Inside Laminations (2)	$1\frac{3}{4}$ " x 4 " x 8 "
17	Pediment Ash Laminations* (10)	$\frac{3}{8}$ " x $1\frac{3}{8}$ " x 72 "
18	Pediment Walnut Laminations* (2)	$\frac{3}{8}$ " x $6\frac{3}{8}$ " x 72 "
19	Lag Bolts (16)	$\frac{3}{8}$ " Dia. x $3\frac{1}{2}$ "

*Sufficient material for headboard and footboard pediment

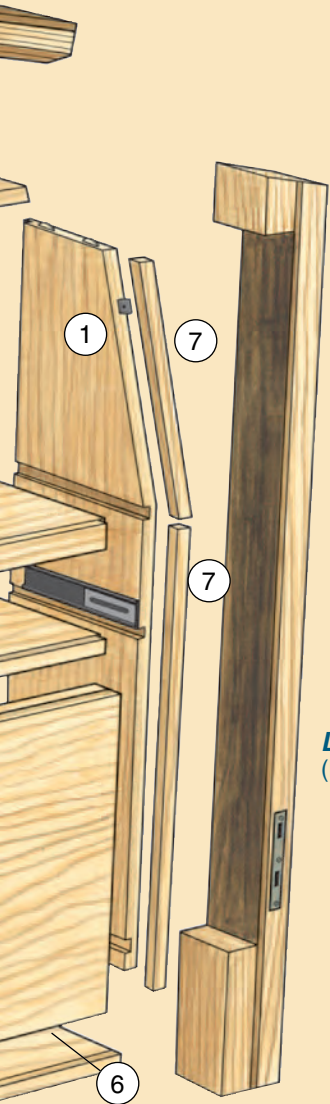

Laminated Leg
(Front Views)

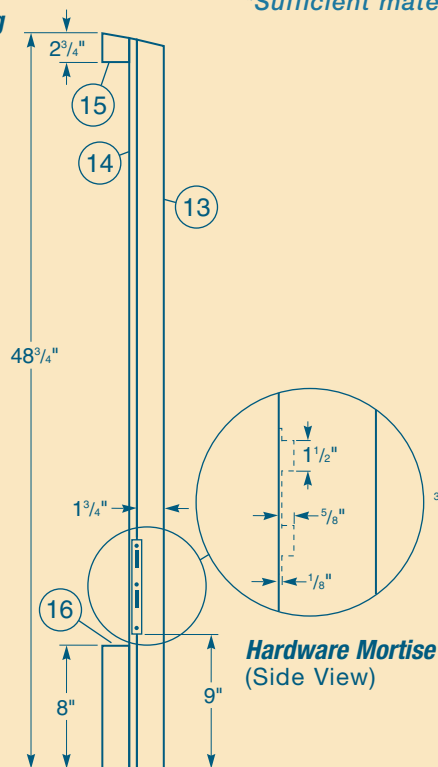

Hardware Mortise
(Side View)

Cabinet Divider
(Side and End Views)

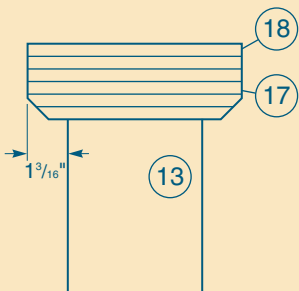
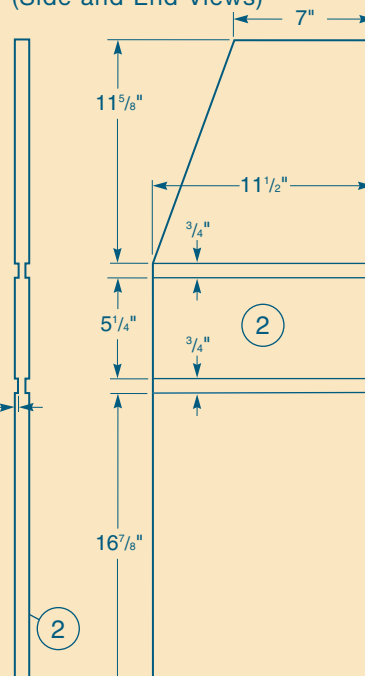

Grab one arched pediment and position it on the headboard subassembly. Mark the leg locations on its underside and bore pilot holes through the piece. Then attach the pediment to the legs, after predrilling for the 3½"-long lag bolts (pieces 19). The reason you're using such large bolts is that people are bound to use the arched pediments as handles to lift the bed, so these joints will be subject to some serious stress. Countersink for the bolt heads, making sure they are below the surface before you proceed to the next step.

Wrap up by gluing and clamping the final (walnut) lamination in place. After the glue dries, use a bearing-guided laminate trimming bit to pare the edges flush with the ash. Sand the edges, and you're ready to move on to the footboard.

Solid-Ash and Walnut Footboard

The only difference between the headboard and footboard (aside from height) is that the latter sports a couple of hardwood panels instead of a cabinet. Construction begins with the legs. Face-glue and clamp two ash laminations (pieces 20) around a walnut one (piece 21), and dress it on the jointer after the glue dries. Do this for each leg and then crosscut them to length. On the router table, plow stopped mortises into the inside faces of the legs and square up the ends of each mortise with a chisel.

Edge-glue hardwood stock to make the footboard panels (pieces 22 and 23), paying attention to the grain pattern. Size the panels to create the upper and lower sections and then plow a ½" groove along the joining edges. Cut the curved shape on the upper edge as shown in the *Elevation Drawings*. Mill the ½" x ½" tenons onto the panels ends with a dado blade in the table saw. Mill the decorative walnut strip (piece 24) that fits between the upper and lower panels to size. Sand both panels (and the walnut strip) to 180 grit, then glue and clamp the panel subassembly between the legs to complete the footboard.

Attach the footboard pediment (which you made earlier) in exactly the same fashion as the headboard version. Apply the final walnut lamination, clean up any glue squeeze-out and sand the edges smooth.

Side Rails and Moldings

There isn't much to the side rail assemblies: they're just a couple of lengths of molding (pieces 25) attached to boards (pieces 26). Rip the moldings to size, then lay out the five dadoes in each, at the locations shown in the *Elevation Drawings*. Make the dado cuts with the aid of your miter gauge. Glue the walnut accent strip (pieces 27) to the top edge of each rail.

After sanding the rails, screw and glue the moldings to them. Form five lengths of stock to serve as the rail slats (pieces 28). These fit into the dadoes in the side rail moldings and will support your box spring once the bed is assembled. Now you're ready to attach the rails to the headboard and footboard. This is done with bedframe hardware designed specifically for this application (pieces 29). It's strong, totally invisible and allows for disassembly when you need to move the bed elsewhere.



Heavy-duty lag bolts ensure that the arched pediments will not come loose from the bed's legs. Make sure you sink the heads below the level of the arch.

Headboard Exploded View

Footboard (Inside and Side Views)

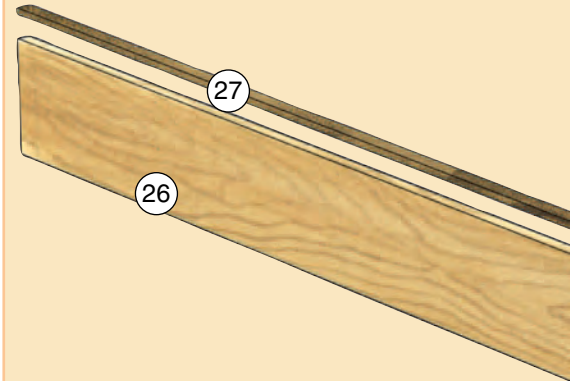
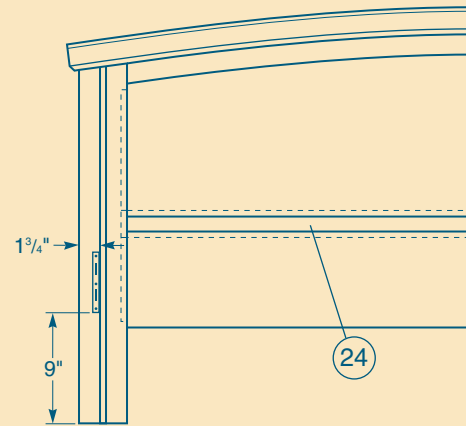

Footboard Panels (Front View)

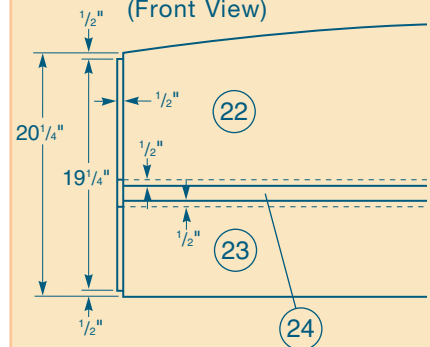

Use the pediment to transfer the arc onto the upper panel.

Side Rail and Molding (Inside View)

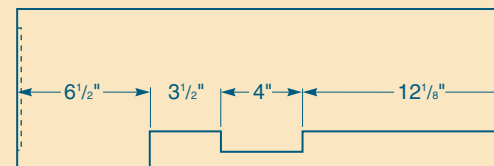

MATERIAL LIST—FOOTBOARD

		T x W x L
20	Short Leg Outside Laminations (4)	1 3/4" x 4" x 30"
21	Short Leg Center Laminations (2)	1/2" x 4" x 30"
22	Footboard Upper Panel (1)	1" x 13 1/2" x 58 1/4"
23	Footboard Lower Panel (1)	1" x 8" x 58 1/4"
24	Footboard Walnut Strip (1)	1/2" x 2 1/4" x 58 1/4"
25	Side Rail Moldings (2)	1" x 2" x 82"
26	Side Rails (2)	1" x 8" x 88 1/2"
27	Side Rail Trim (2)	1/2" x 1" x 88 1/2"
28	Rail Slats (5)	1" x 4" x 61 1/4"
29	Bed Hardware (4 Sets)	Steel inset

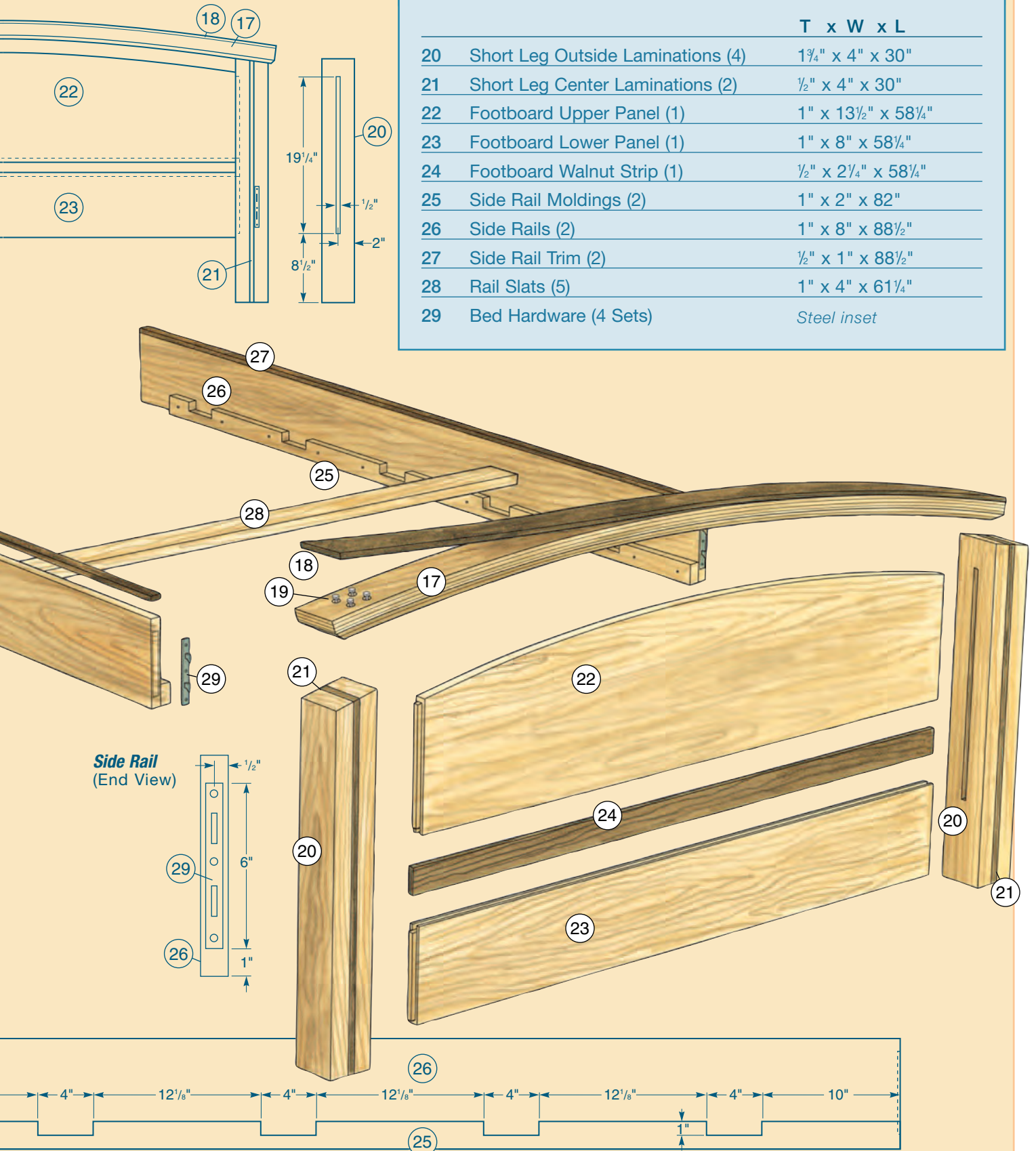

Tilting Door Exploded View

MATERIAL LIST—DOORS AND DRAWERS

		T x W x L
30	Large Drawer Fronts & Backs (4)	1/2" x 4" x 23"
31	Small Drawer Fronts & Backs (2)	1/2" x 4" x 7 1/2"
32	Drawer Sides (6)	1/2" x 4" x 12"
33	Large Drawer Bottoms (2)	1/4" x 11 1/2" x 23"
34	Small Drawer Bottom (1)	1/4" x 7 1/2" x 11 1/2"
35	Large Drawer Faces (2)	3/4" x 6" x 26 3/16"
36	Small Drawer Face (1)	3/4" x 6" x 9 5/8"
37	Large Tilting Doors (2)	1" x 17 3/16" x 26 3/16"
38	Small Tilting Door (1)	1" x 17 3/16" x 9 5/8"
39	Drawer Slides (3 Pairs)	Accuride™ full extension
40	Door Hinges (3 Pairs)	1 1/2" Brass piano
41	Door Catches (3)	Magnetic

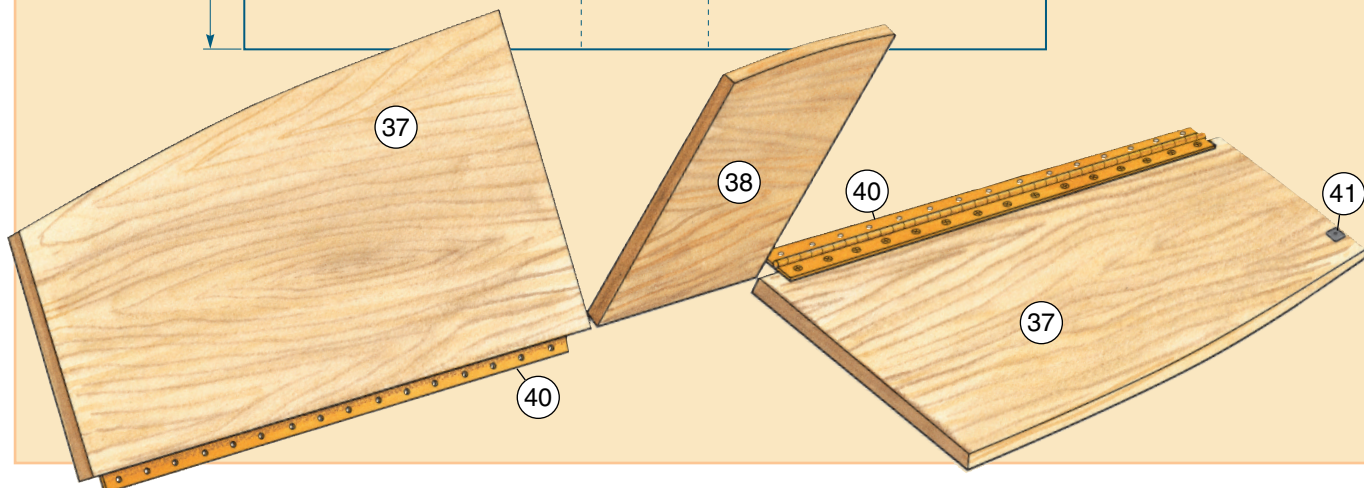
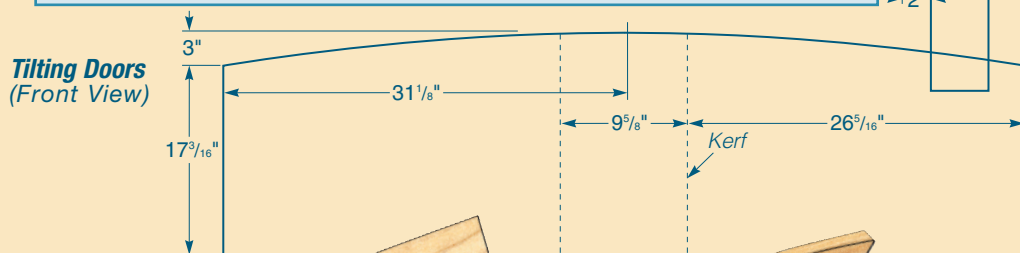
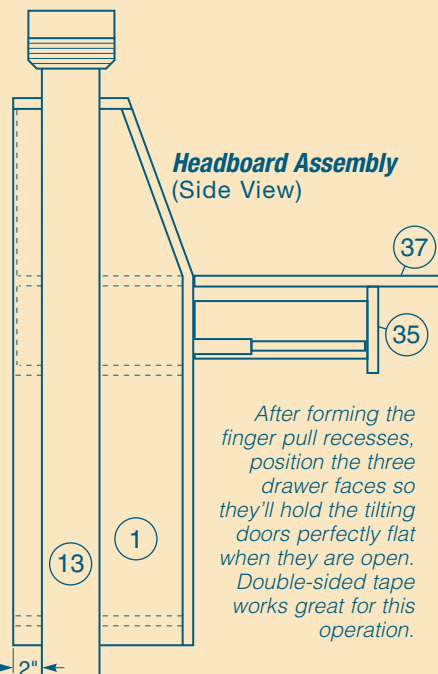

Putting It All Together. Heavy-duty drawer slides are an important feature, as the drawers (when open) do double duty as door supports.



Sewing machine hinges were tested, but they weren't up to the job. Piano hinges offer the strength and support these doors need.



Installing knock-down bed rail hardware in mortises keeps it invisible when assembled.

Drawer Exploded View

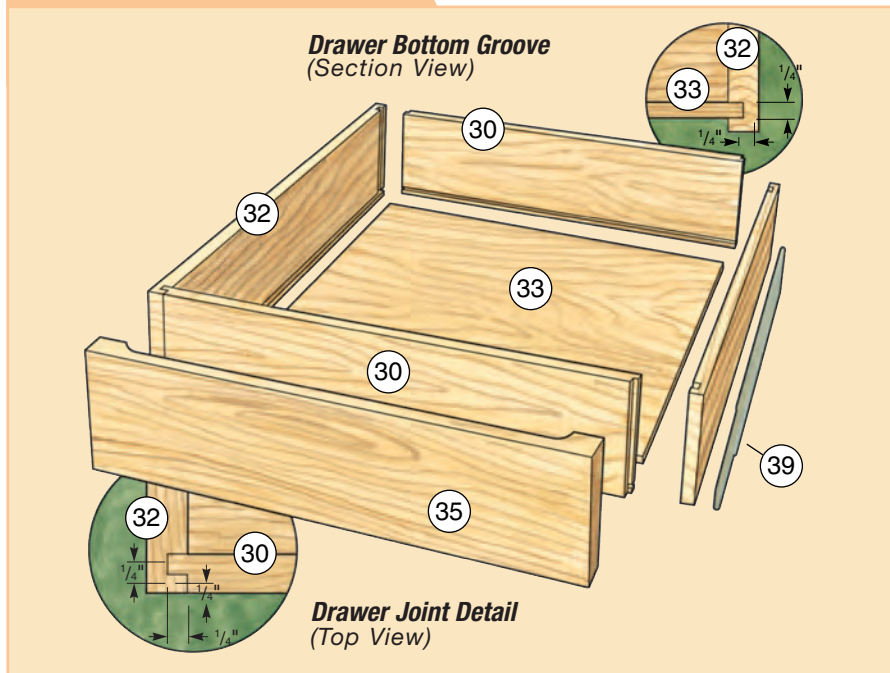

Three Drawers for Storage

Our bed features three 12"-deep drawers, two of which are ideal for storing stationery and reading materials. The third, smaller drawer is designed for reading glasses, pens and similar items.

Cut the drawer fronts, backs and sides (pieces 30 through 32) to size, then chuck a 1/4" straight bit in the router table. Plow a through-groove in each part for the drawer bottoms (pieces 33 and 34), as shown above. Next, mill a vertical dado in the drawer sides near each end on the same face as the drawer bottom groove. Each dado is 1/4" square and located 1/4" from the end.

Use the same 1/4" router bit to cut rabbets on the ends of the drawer fronts to make a slick, locking corner joint. Dry-fit the drawers together. When everything works, assemble the drawers with glue and clamps. Make sure they're flat and square.

Solid-Hardwood Drawer Faces

You'll give your bed a great look if you arrange a continuous grain pattern through the hardwood drawer faces (pieces 35 and 36) and the tilting doors above them (pieces 37 and 38). If you edge-glide stock to pro-

duce this effect, match the grain along the joint so it looks as though all six parts were cut from the same board.

Following the manufacturer's instructions, use heavy-duty, full-extension drawer slides (pieces 39) to install the three drawers in their openings. Full-extension slides allow the drawers to pull out far enough to support the doors above them. The heavy-duty rating means that even an unabridged edition of *War and Peace* won't cause them to sag. Hold off on mounting the drawer faces until the doors are in place.

Uniquely Designed Tilting Doors

The three tilting doors in the headboard are what really fulfill a reader's dreams. All three conceal cavities large enough to store plenty of printed matter, while either of the larger doors drops down to become an instant desk (depending on which side of the bed you prefer). The smaller, middle door transforms into a shelf for popcorn or a remote control.

You have already glued up stock for the doors. Now cut them to size. Rip and crosscut first, then arch the tops on the band saw. Belt-sand the

saw marks away, then sand all three doors and break their edges gently with 180-grit sand paper.

Mount the doors using heavy-duty piano hinges (pieces 40). Mark the locations of the hinges on the doors and the headboard. Install just a couple of screws per hinge to assure you have the alignment right. Once you're sure all is correct, install the remaining screws. When the doors fit nicely, mount the magnetic door catches (pieces 41) to keep the doors from accidentally opening. With all three drawers mounted in their openings and fully extended, open the tilting doors. Locate the drawer faces so they'll support the doors at a true 90°.

Use double-sided tape or hot-melt glue to temporarily locate and attach the drawer faces and make sure they're properly spaced left to right. Remove the drawers and secure the faces with screws, working from inside the drawers. Predrill and countersink for your screws. When the holes are all drilled, remove the faces and use a 3/4" corebox bit mounted in your router table to create the finger pulls. Clamp stops to the fence to keep the recesses spaced about 1" in from each end.

Final Touches and Finishing

The only thing left to do before you pull out the mattress and take a nap is to apply a finish. Remove the drawers, then sand everything down to 220 grit. Use a tack cloth to remove the dust, and apply a coat of clear sanding sealer. Follow this with three coats of satin polyurethane, sanding lightly between each coat with 400-grit wet/dry paper.

