

Bagel Slicer

by Victor F. Ptasnik

While this kitchen accessory will become an attractive conversation piece for the cook's guests, it's really designed to allow the user to slice bagels safely. With the ever increasing popularity of these donut shaped breads, you should also find it to be a marketable item. Cherry was used, but any other dense hardwood that's suitable for turning can be substituted. Cut your material to the exact dimensions, making sure that the grain on parts A, B, and C runs in the same direction.

The jaws, parts A & B, are made first. Cut each one from 1" stock ($\frac{3}{4}$ " actual) to a $5\frac{1}{2}$ " square. A lathe equipped with a faceplate will cut the $3\frac{1}{2}$ " diameter contoured face on each jaw. Note that the $3\frac{1}{2}$ " diameter contour is exactly in the center of the $5\frac{1}{2}$ " square.

To achieve a uniform shape on all three pieces and, more importantly, to precisely locate the dowels, you will need to temporarily hold together parts A, B & C for machining. One solution is to use common nails. At the centerpoint of each dowel location, accurately drill a hole just large enough to hold a two-inch long nail. Held together by these three nails, the resulting stack of wood can be cut to the bell shape with a bandsaw or jigsaw. Then remove one nail at a time and, with a drill press, drill a $\frac{1}{2}$ " hole using the nail hole as a guide. Insert a dowel and drill out the remaining two holes in the same manner. After removing the dowels, enlarge the holes in part B with a rasp so that it can freely slide on the dowels.

Use a router equipped with a $\frac{1}{4}$ " rounding-over bit to round all edges except those on the base surface. With part B in place, glue the dowels into parts A and C. Flush sand the dowel ends.

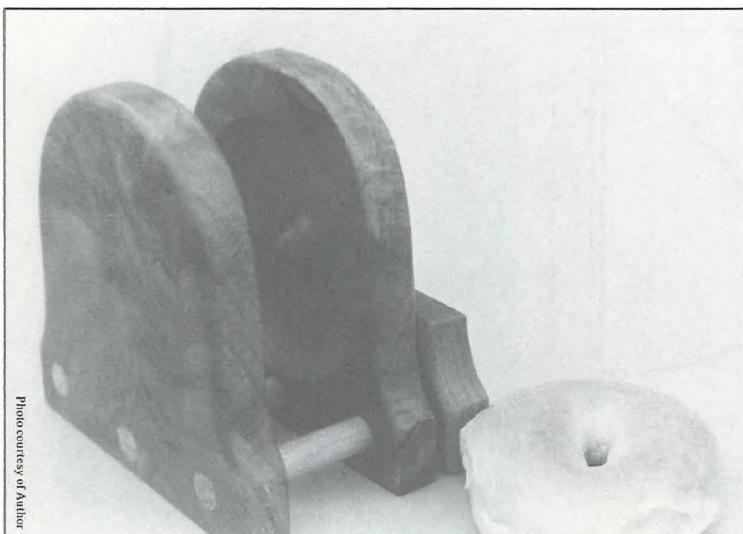
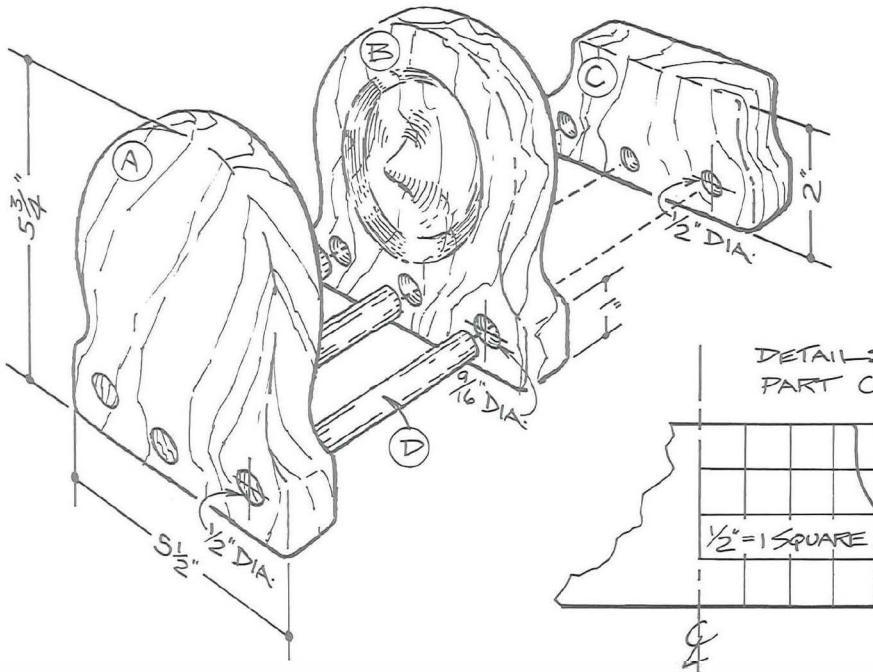
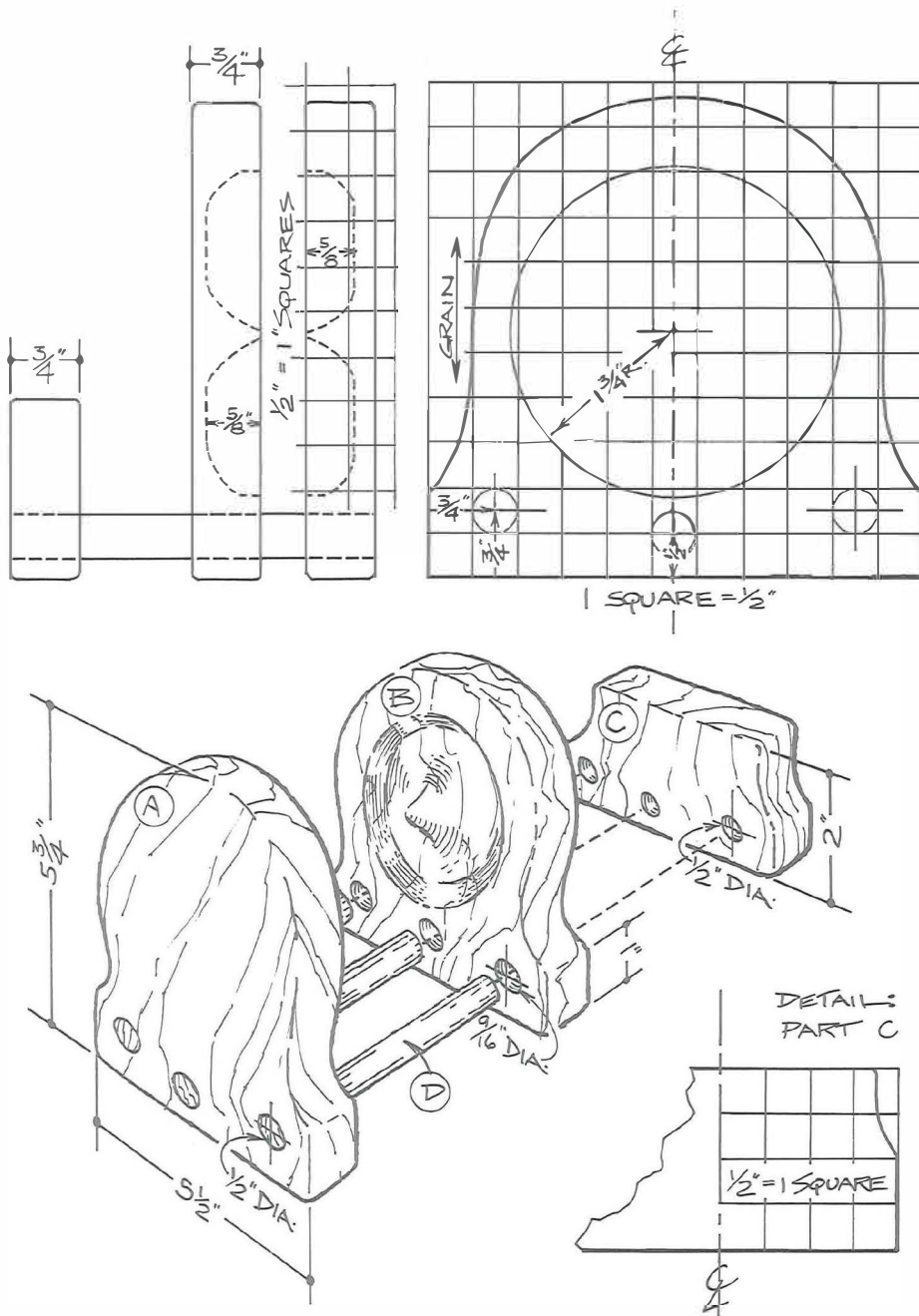

Photo courtesy of Author

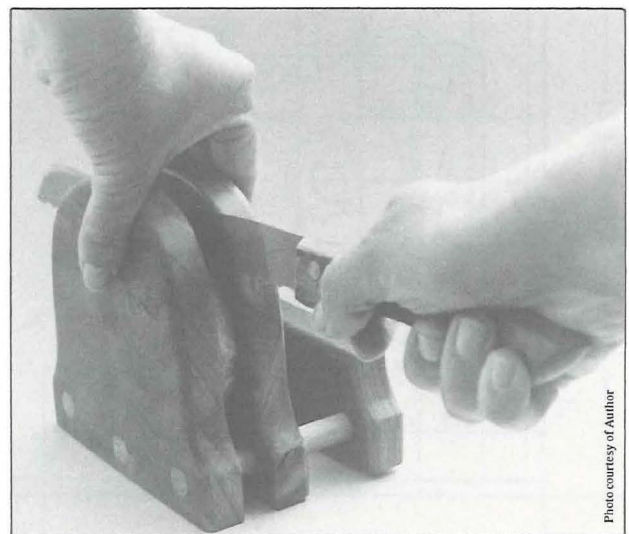

Photo courtesy of Author