

Exploded View

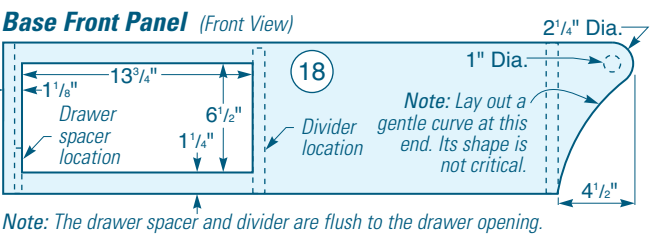

MATERIAL LIST	T x W x L
1 Front (1)	3/4" x 6 1/4" x 34 1/2"
2 Back (1)	3/4" x 6" x 34 1/2"
3 Ends (2)	3/4" x 6" x 13 1/2"
4 End Cleats (2)	3/4" x 2" x 13 1/2"
5 Front, Back Cleats (4)	3/4" x 3/4" x 10"
6 Bottom Panels (2)	1/4" x 13 1/2" x 16 3/8"
7 Glue Blocks (2)	3/4" x 3/4" x 2"
8 Center Support (1)	3/4" x 1 1/4" x 13 1/2"
9 Top (1)	3/4" x 18 1/2" x 38"
10 End Wings (2)	3/4" x 6" x 14 1/2"
11 Cherry Trim (1)	1/4" x 3/4" x 254"
12 Magnets, Magnet Washers (2 Pr.)	3/4" Dia.
13 Piano Hinges (2)	1 1/2" x 36"
14 Barrel Latches (2)	1 1/2" x 1 1/2"
15 4" Dust Ports (3)	3" x 6 1/4" x 6 1/4"
16 Short End Panel (1)	3/4" x 13 1/2" x 27"
17 Tall End Panel (1)	3/4" x 13 1/2" x 33"
18 Base Front and Back Panels (2)	3/4" x 9" x 37 1/2"
19 Lower Shelf (1)	3/4" x 12 3/4" x 31 1/2"
20 Handle (1)	1" Dia. x 14 1/4" Dowel
21 Divider (1)	3/4" x 8 1/2" x 13 1/2"
22 Lower Stretchers (2)	3/4" x 8 1/2" x 31 1/2"
23 Casters (2)	5" Plate Casters

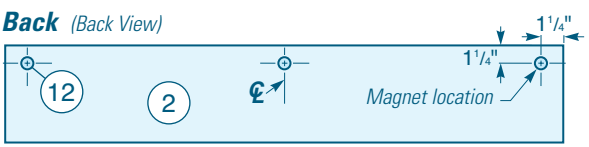
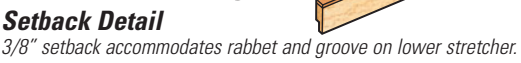
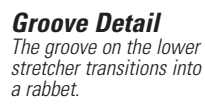
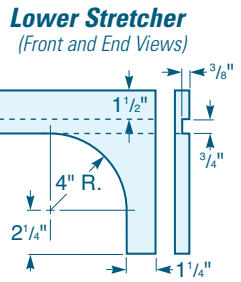
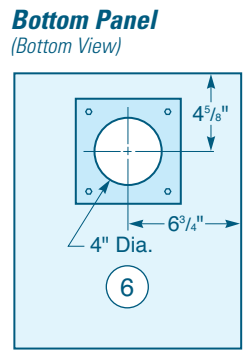
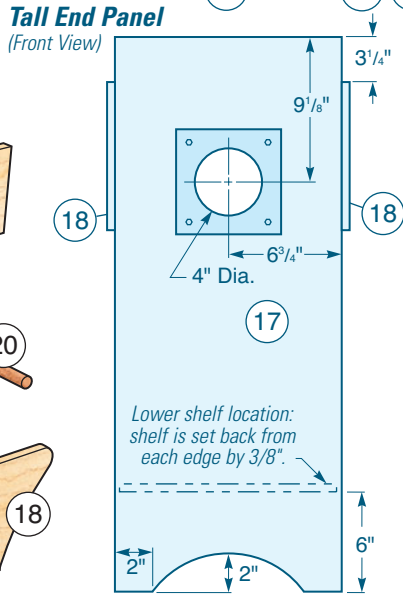
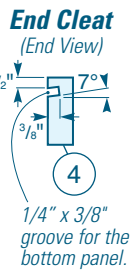
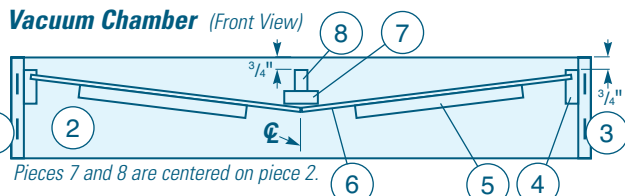
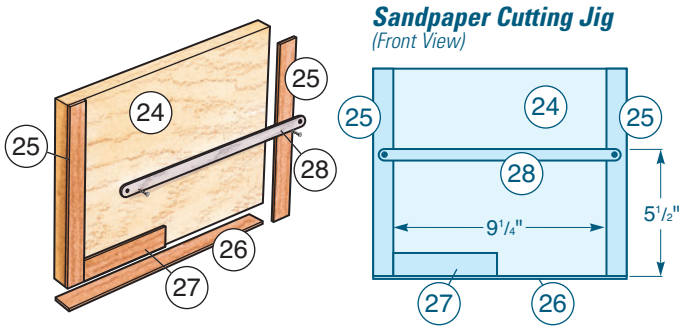

Note: Drawer spacer (piece 33) location is shown in drawing on opposite page.

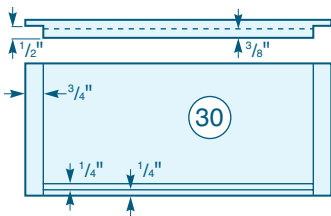
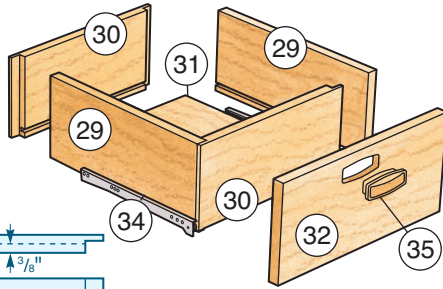

MATERIAL LIST

Sandpaper Cutter		T x W x L
24	Base (1)	3/4" x 9" x 11"
25	Side Trim (2)	1/8" x 7/8" x 9"
26	Bottom Trim (1)	1/8" x 1" x 11"
27	Front Bottom Trim (1)	1/8" x 1" x 4 1/2"
28	Hacksaw Blade (1)	Standard
Drawer		T x W x L
29	Drawer Sides (2)	3/4" x 5 1/2" x 13 3/8"
30	Drawer Front and Back (2)	3/4" x 5 1/2" x 12 3/4"
31	Drawer Bottom (1)	1/4" x 12" x 13 1/8"
32	Drawer Face (1)	3/4" x 7" x 14 1/2"
33	Drawer Spacer (1)	3/8" x 3" x 13 1/2"
34	Drawer Slides (2)	Blum 12"
35	Drawer Pull (1)	Wooden Inset