

### Left Side

(Inside View)

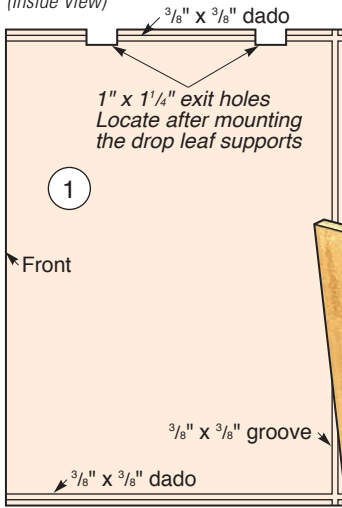

### Exploded View

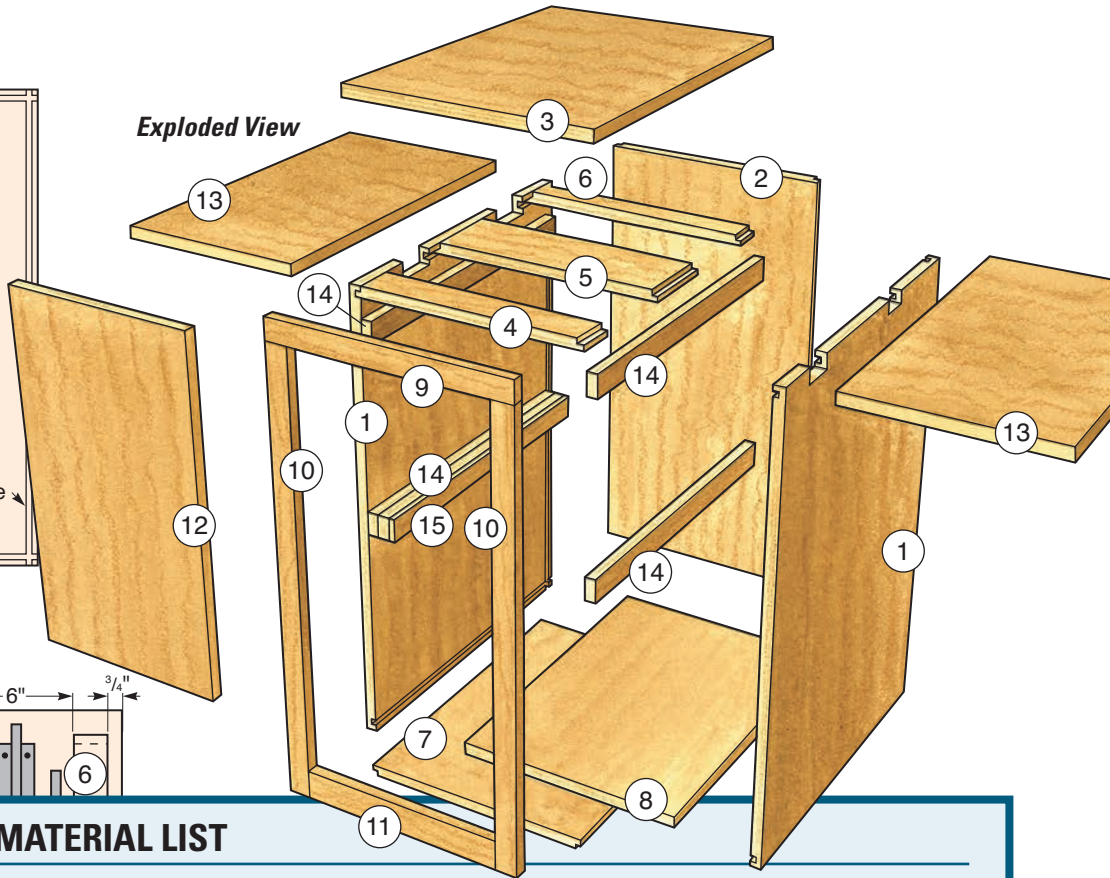

### Sub-top Locations

(Bottom View)

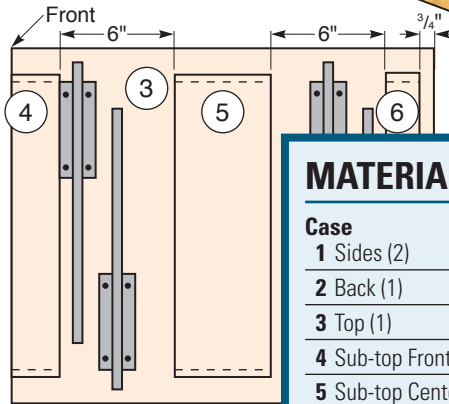

## MATERIAL LIST

### Case

	T x W x L		T x W x L
1 Sides (2)	$\frac{3}{4}$ " x 22" x 31"	9 Face Frame Top Rail (1)	$\frac{3}{4}$ " x $1\frac{1}{2}$ " x $16\frac{1}{2}$ "
2 Back (1)	$\frac{3}{4}$ " x $15\frac{3}{4}$ " x 31"	10 Face Frame Stiles (2)	$\frac{3}{4}$ " x $1\frac{1}{2}$ " x $30\frac{1}{4}$ "
3 Top (1)	$\frac{3}{4}$ " x $18\frac{1}{2}$ " x 22"	11 Face Frame Bottom Rail (1)	$\frac{3}{4}$ " x 2" x $13\frac{1}{2}$ "
4 Sub-top Front (1)	$\frac{3}{4}$ " x $2\frac{1}{2}$ " x $15\frac{3}{4}$ "	12 Door (1)	$\frac{3}{4}$ " x $13\frac{3}{8}$ " x $24\frac{1}{8}$ "
5 Sub-top Center (1)	$\frac{3}{4}$ " x 5" x $15\frac{3}{4}$ "	13 Wings (2)	$\frac{3}{4}$ " x $12\frac{5}{8}$ " x 22"
6 Sub-top Back (1)	$\frac{3}{4}$ " x $1\frac{3}{4}$ " x $15\frac{3}{4}$ "	14 Drawer, Tray Spacers (5)	$\frac{3}{4}$ " x $1\frac{1}{2}$ " x $21\frac{1}{4}$ "
7 Structural Bottom (1)	$\frac{3}{4}$ " x $15\frac{3}{4}$ " x $21\frac{1}{4}$ "	15 Thin Tray Spacer (1)	$\frac{3}{8}$ " x $1\frac{1}{2}$ " x $21\frac{1}{4}$ "
8 Bottom (1)	$\frac{3}{4}$ " x 15" x $21\frac{1}{4}$ "		

All the joinery for the drawer and shelf are  $\frac{3}{8}$ " x  $\frac{3}{8}$ " rabet-and-dadoes

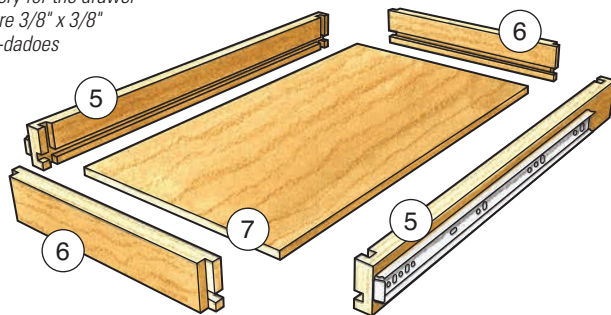
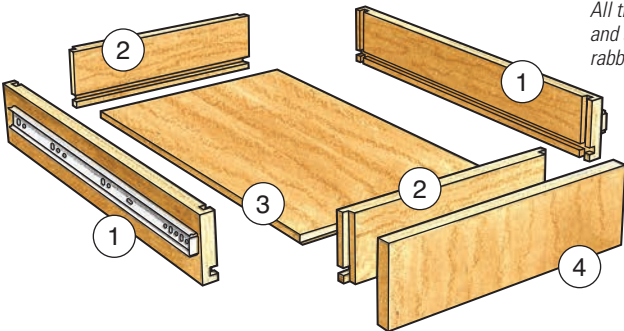

## MATERIAL LIST

### Drawer and Shelf

	T x W x L
1 Drawer Sides (2)	$\frac{3}{4}$ " x $3\frac{3}{8}$ " x 21"
2 Drawer Front and Back (2)	$\frac{3}{4}$ " x $3\frac{3}{8}$ " x $11\frac{3}{4}$ "
3 Drawer Bottom (1)	$\frac{3}{4}$ " x $11\frac{3}{4}$ " x $20\frac{1}{4}$ "
4 Drawer Face (1)	$\frac{3}{4}$ " x 4" x $13\frac{3}{8}$ "
5 Shelf Sides (2)	$\frac{3}{4}$ " x 2" x 21"
6 Shelf Front and Back (2)	$\frac{3}{4}$ " x 2" x $10\frac{5}{8}$ "
7 Shelf Bottom (1)	$\frac{3}{4}$ " x $10\frac{5}{8}$ " x $20\frac{1}{4}$ "