

Exploded View

MATERIAL LIST

	T x W x L
1 Seat Frames (2)	3/4" x 5 1/2" x 38 1/2"
2 Back Stretcher (1)	3/4" x 3 1/2" x 18 1/2"
3 Seat Slats (11)	3/4" x 1 1/2" x 20"
4 Front Legs (2)	3/4" x 5 1/2" x 20"
5 Back Legs (2)	3/4" x 3 1/2" x 25 1/2"
6 Front Stretcher (1)	3/4" x 3 1/2" x 20"
7 Upper Back Frame (1)	3/4" x 5" x 22"
8 Lower Back Frame (1)	3/4" x 3 1/2" x 20"
9 Back Slats (7)	3/4" x 2 3/4" x 32"
10 Arms (2)	3/4" x 7 1/4" x 31"
11 Braces (2)	3/4" x 3 1/2" x 7 1/2"

Slat Layout

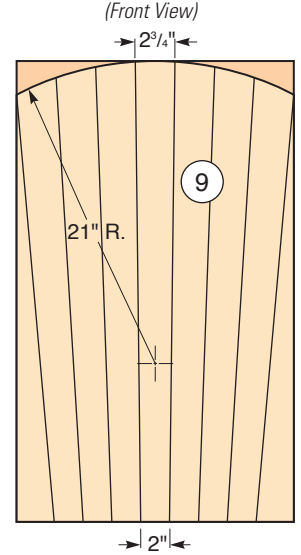

Patterns

(Each square = 1")

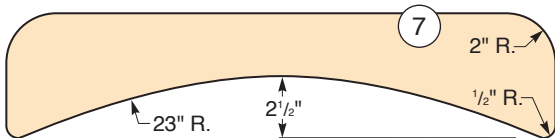
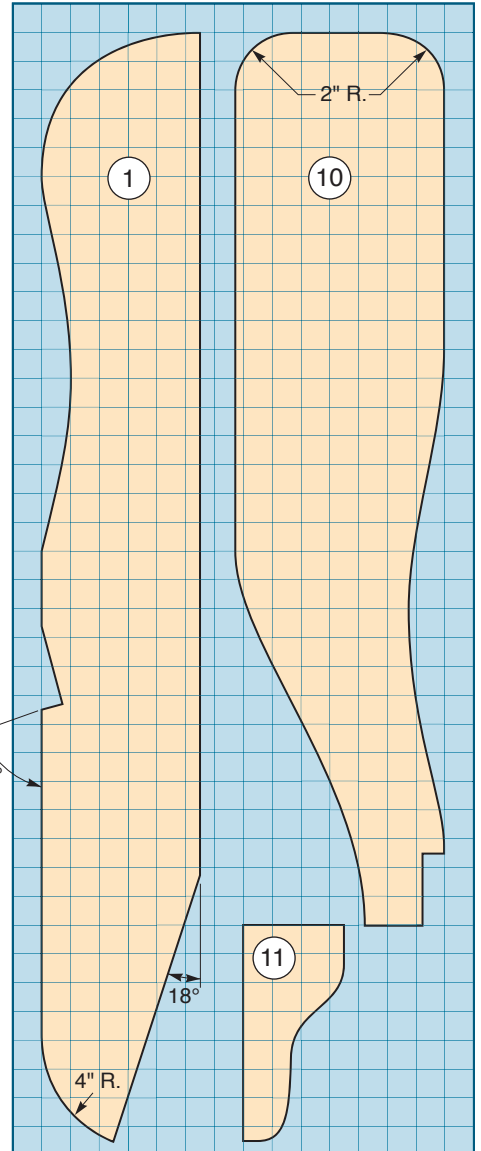

Upper Back Frame
(Top View)

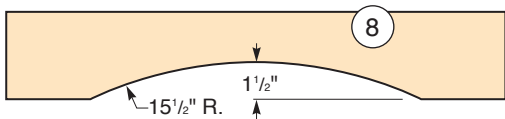

Lower Back Frame
(Top View)

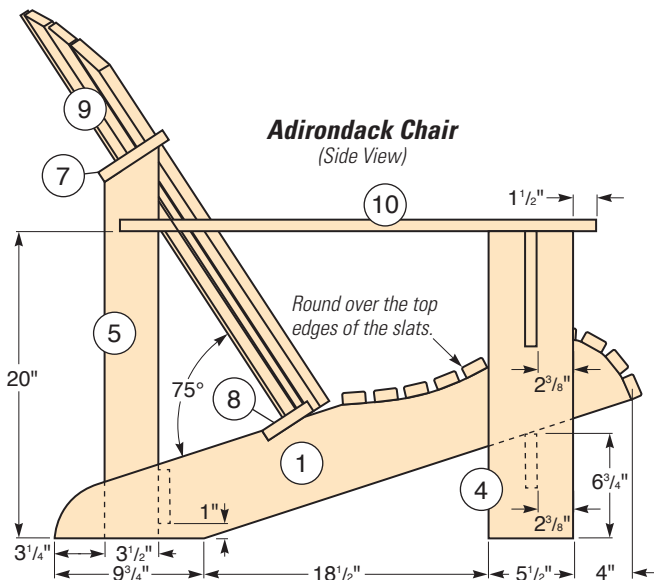

Adirondack Chair
(Side View)