

Brace Platform
(Top View)

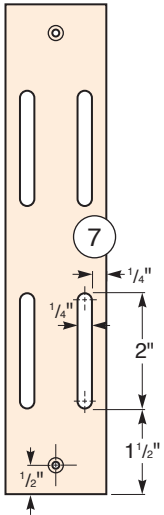

Bolt Location
(Side View)

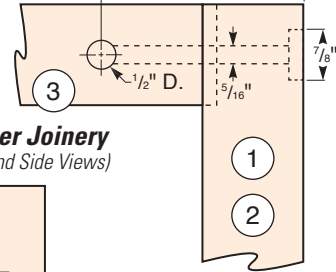

Corner Joinery
(End and Side Views)

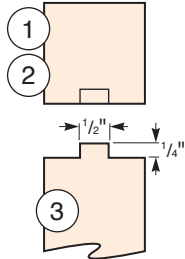

Star Knob Hole Location
(Side View)

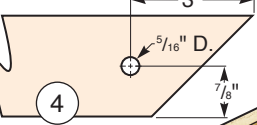

Threaded Insert Location
(Side View)

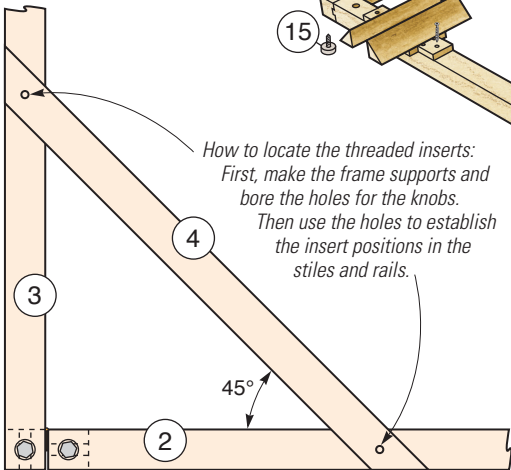

How to locate the threaded inserts:
First, make the frame supports and bore the holes for the knobs.
Then use the holes to establish the insert positions in the stiles and rails.

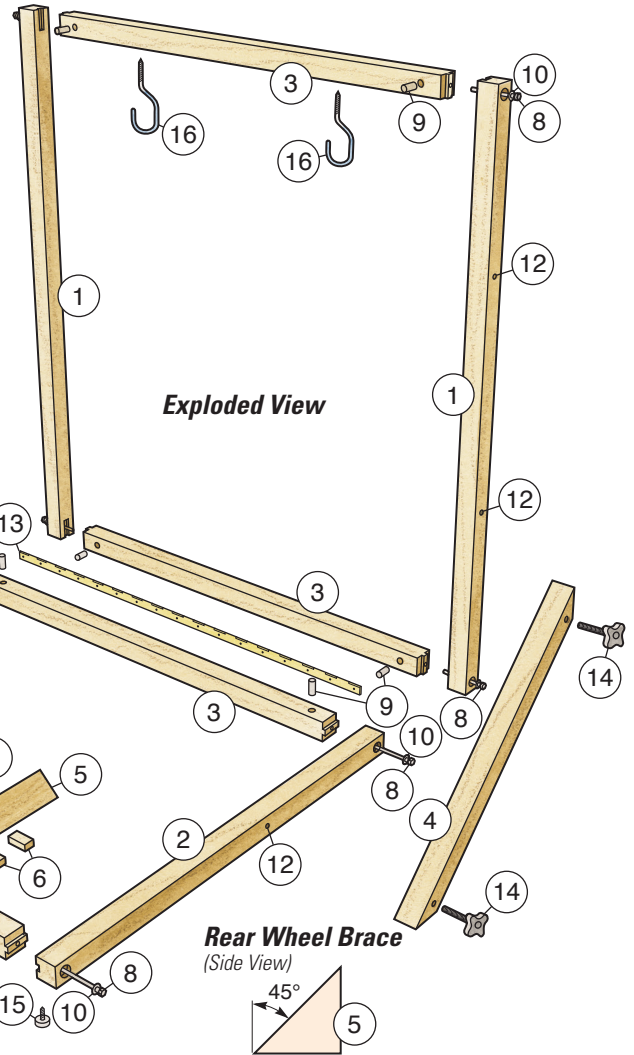

Exploded View

Rear Wheel Brace
(Side View)

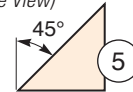

MATERIAL LIST

	T x W x L
1 Vertical Stiles (2)	1 3/4" x 1 3/4" x 50"
2 Base Stiles (2)	1 3/4" x 1 3/4" x 36"
3 Rails (4)	1 3/4" x 1 3/4" x 39"
4 Frame Supports (2)	3/4" x 1 3/4" x 26"
5 Rear Wheel Braces (4)	1 1/2" x 1 1/2" x 8"
6 Brace Guides (8)	1/2" x 3/4" x 1 1/2"
7 Brace Platforms (2)	1/2" x 1 3/4" x 8 1/2"

Hardware

8 5/16"-18 x 4" Bolts (8)	
9 5/16"-18 x 1/2" dia. Cross Dowels (8)	
10 5/16" Flat Washers (8)	
11 No. 8 x 1 1/4" Flathead Screws (20)	Rockler #29165
12 5/16-18 Threaded Inserts (5)	Rockler #28811
13 1 1/16" x 36" Piano Hinge (1)	Rockler #19241
14 5/16"-18 Four-star Knobs (4)	Rockler #54545
15 Gripper Feet (4)	Rockler #44219
16 Bike Hanger Hooks (2)	

To purchase these and other products online, visit www.woodworkersjournal.com/hardware Or, call 800-610-0883 (code WJ1577).