

**Half-blind Dovetail**  
(Front View)

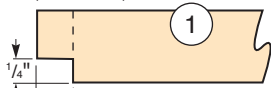

Form a rabbet as shown before cutting the half-blind dovetails.

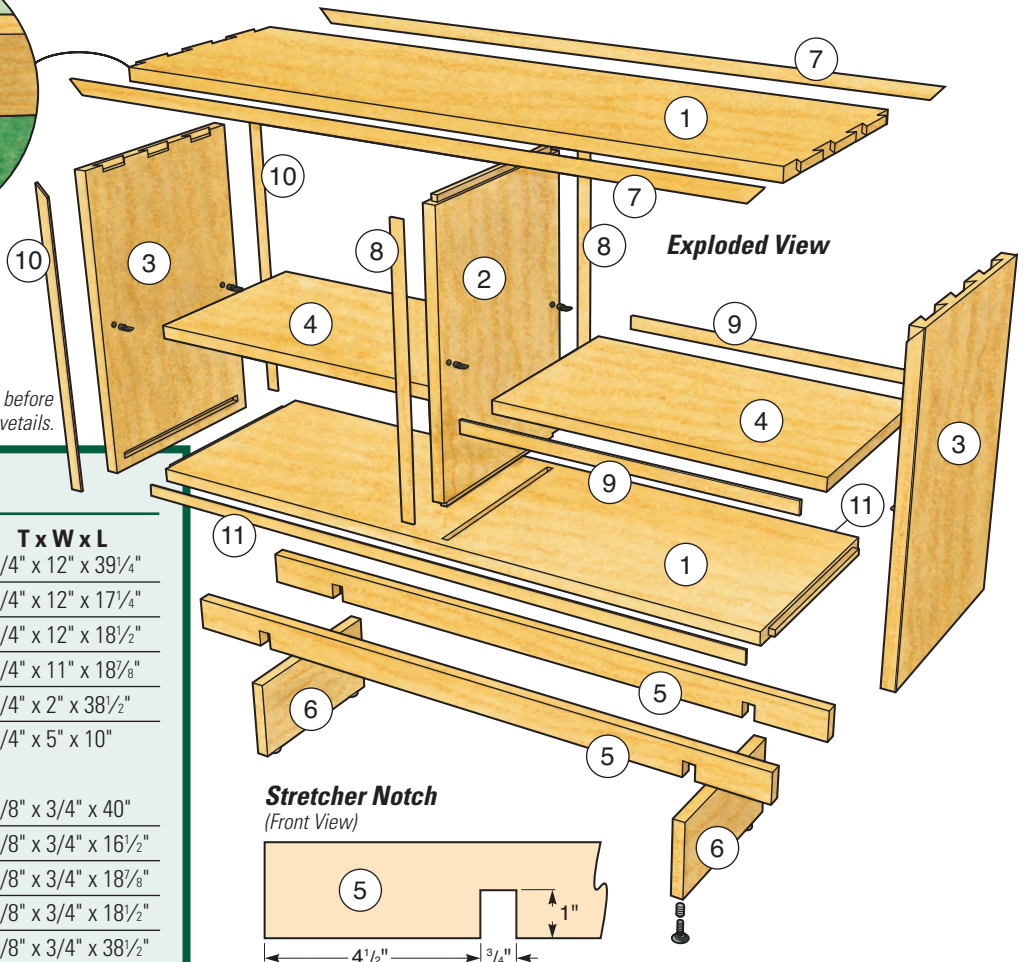

**Exploded View**

**Stretcher Notch**  
(Front View)

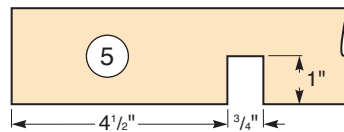

**MATERIAL LIST**

**Case**

|                      | T x W x L            |
|----------------------|----------------------|
| 1 Top and Bottom (2) | 3/4" x 12" x 39 1/4" |
| 2 Divider (1)        | 3/4" x 12" x 17 1/4" |
| 3 Sides (2)          | 3/4" x 12" x 18 1/2" |
| 4 Shelves (2)        | 3/4" x 11" x 18 7/8" |
| 5 Stretchers (2)     | 3/4" x 2" x 38 1/2"  |
| 6 Feet (2)           | 3/4" x 5" x 10"      |

**Edge Banding**

|                      |                       |
|----------------------|-----------------------|
| 7 Top Strips (2)     | 1/8" x 3/4" x 40"     |
| 8 Divider Strips (2) | 1/8" x 3/4" x 16 1/2" |
| 9 Shelf Strips (4)   | 1/8" x 3/4" x 18 1/8" |
| 10 Side Strips (4)   | 1/8" x 3/4" x 18 1/2" |
| 11 Bottom Strips (2) | 1/8" x 3/4" x 38 1/2" |

**Side**

(Top and Inside Views)

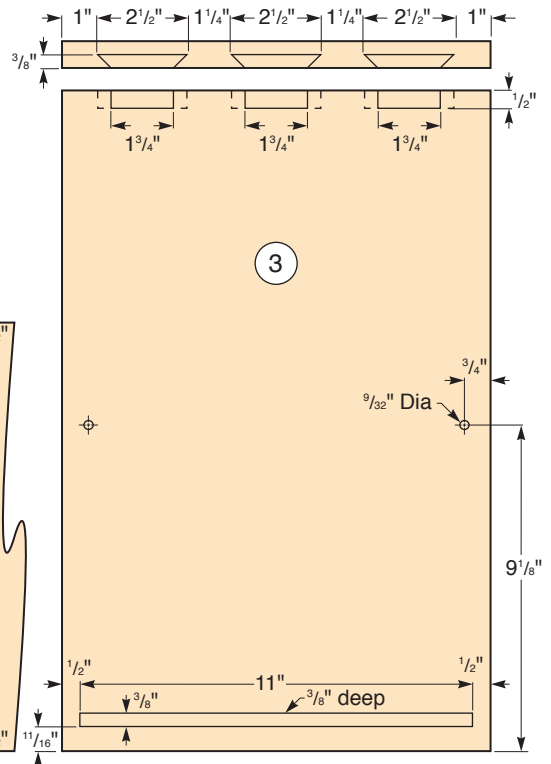

**Bottom**  
(Top View)

