

Tube Routing Jig Elevations

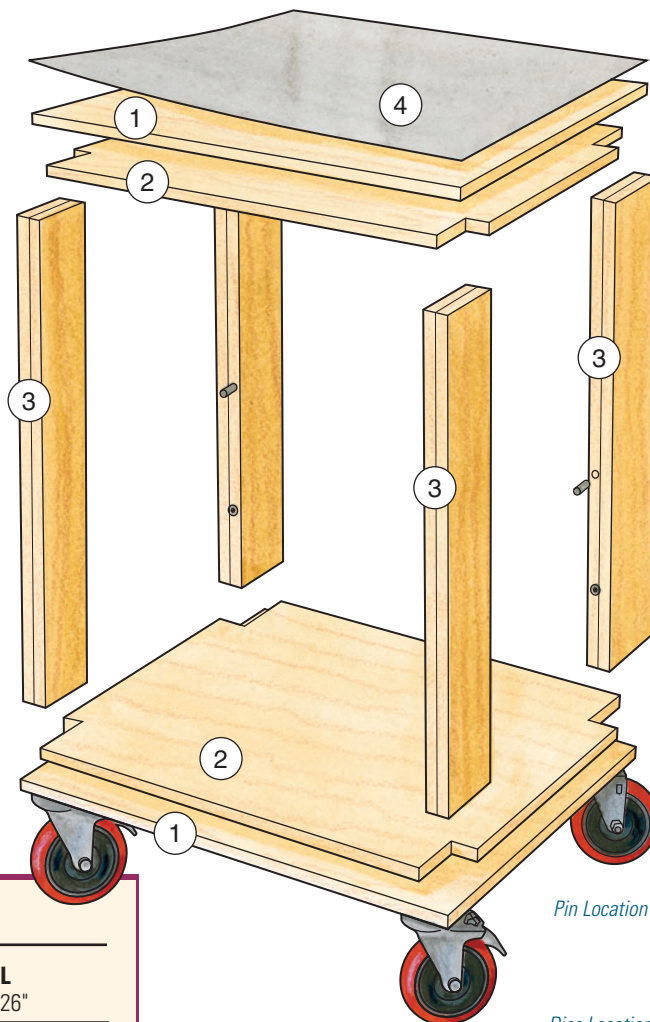

Inner Panel (Top View)

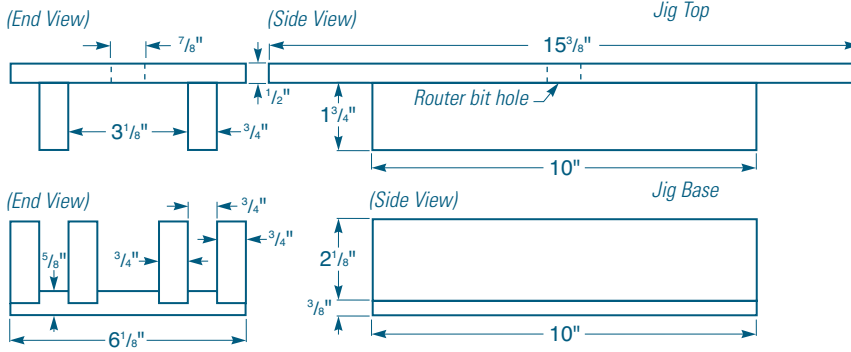
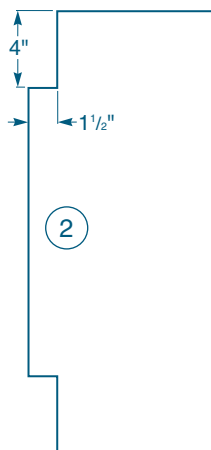

Leg (Side and Edge Views)

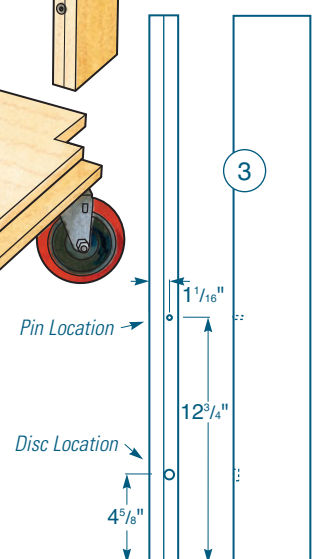

MATERIAL LIST (ROLLING CART)

	T x W x L
1 Top/Bottom (2)	3/4" x 23" x 26"
2 Inner Panels (2)	3/4" x 23" x 26"
3 Leg Components (8)	3/4" x 4" x 28 1/2"
4 Aluminum Top (1)	1/8" x 23" x 26"

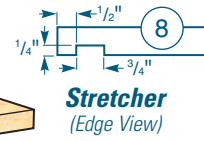
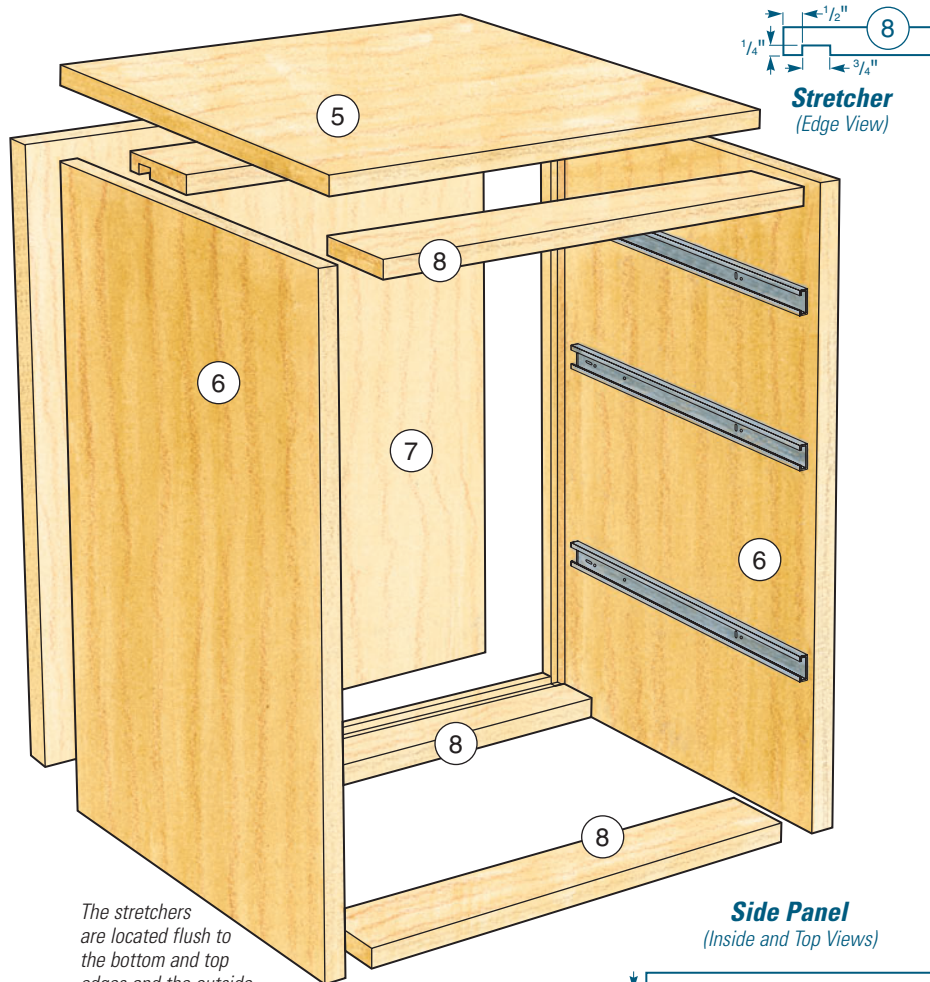

The stretchers are located flush to the bottom and top edges and the outside corners of the sides.

Side Panel
(Inside and Top Views)

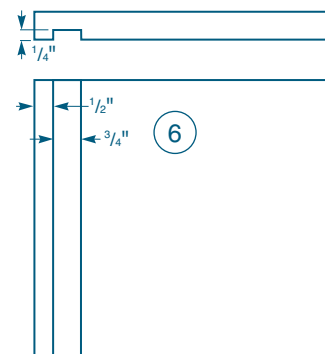

MATERIAL LIST (DRAWER CASE)	
	T x W x L
5 Top (1)	3/4" x 18" x 15 5/8"
6 Sides (2)	3/4" x 17 1/4" x 23 1/4"
7 Back (1)	3/4" x 15" x 23 1/4"
8 Stretchers (4)	3/4" x 4" x 14 1/2"

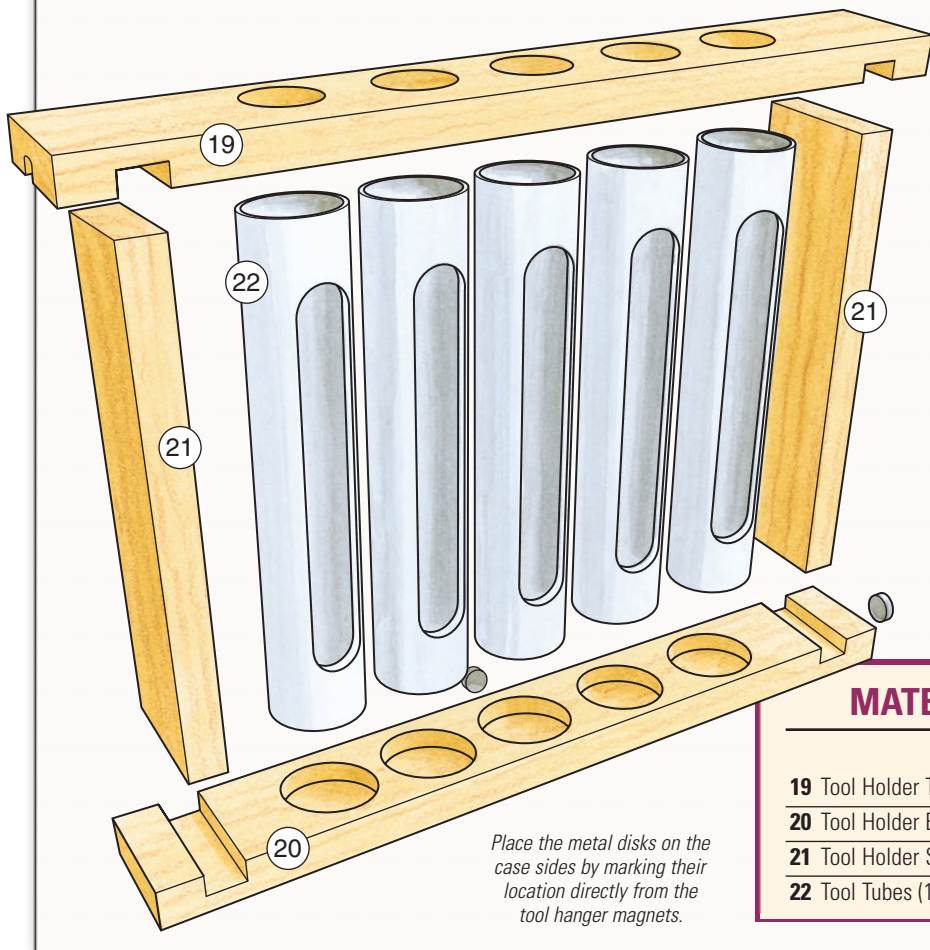

Tool Holder Top
(Bottom View)

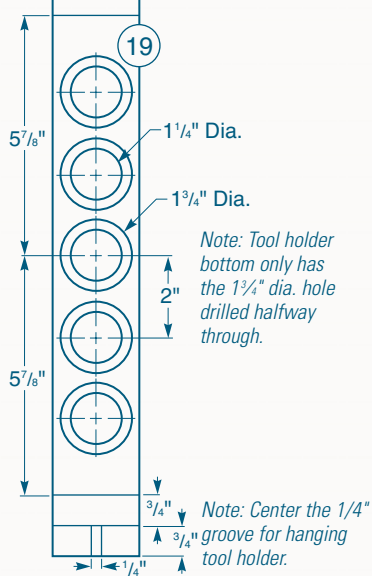

Place the metal disks on the case sides by marking their location directly from the tool hanger magnets.

MATERIAL LIST (TOOL HOLDERS)

	T x W x L
19 Tool Holder Tops (2)	3/4" x 2 1/8" x 14 3/4"
20 Tool Holder Bottoms (2)	3/4" x 2 1/8" x 14 3/4"
21 Tool Holder Sides (4)	3/4" x 2 1/8" x 8 1/2"
22 Tool Tubes (10)	1 5/8" Dia. x 8 1/2"

Drawer Sides
(Top and Inside Views)

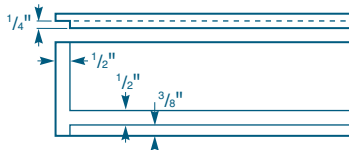

Drawer Handle Cutouts
(Front View)

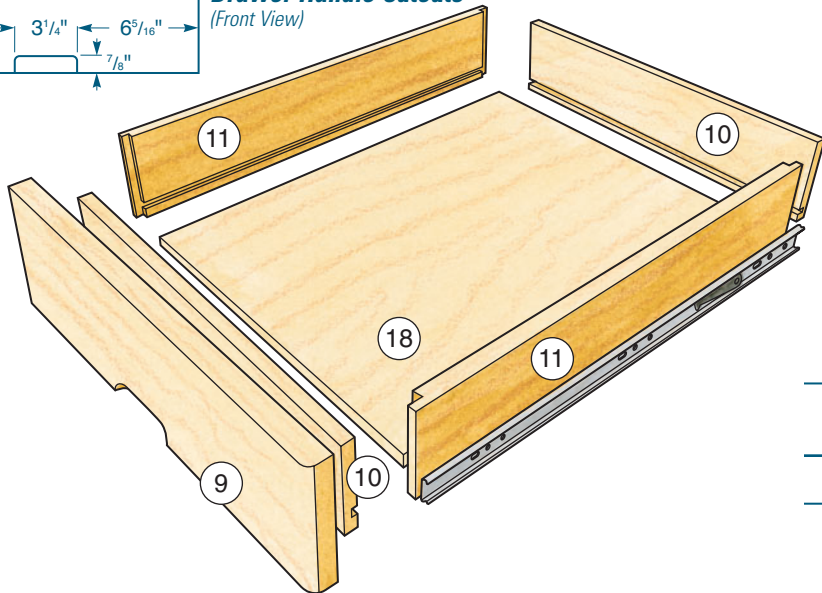
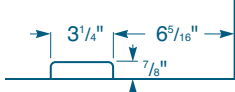

MATERIAL LIST (DRAWERS)

	T x W x L
9 Top Drawer Face (1)	3/4" x 4 1/2" x 15 5/8"
10 Top Drawer Front/Back (2)	1/2" x 3 1/4" x 13"
11 Top Drawer Sides (2)	1/2" x 3 1/4" x 16"
12 Middle Drawer Face (1)	3/4" x 7 3/4" x 15 5/8"
13 Middle Drawer Front/Back (2)	1/2" x 7 3/4" x 13"
14 Middle Drawer Sides (2)	1/2" x 7 3/4" x 16"
15 Bottom Drawer Face (1)	3/4" x 10 1/4" x 15 5/8"
16 Bottom Drawer Front/Back (2)	1/2" x 10 1/4" x 13"
17 Bottom Drawer Sides (2)	1/2" x 10 1/4" x 16"
18 Drawer Bottoms (3)	1/2" x 13" x 15 1/2"

Drawer Joinery

Ease the drawer face edges with a 1/2" dia. roundover bit.

