

Shelf Support

(Top View)

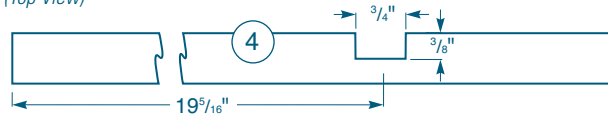

Brace

(End View)

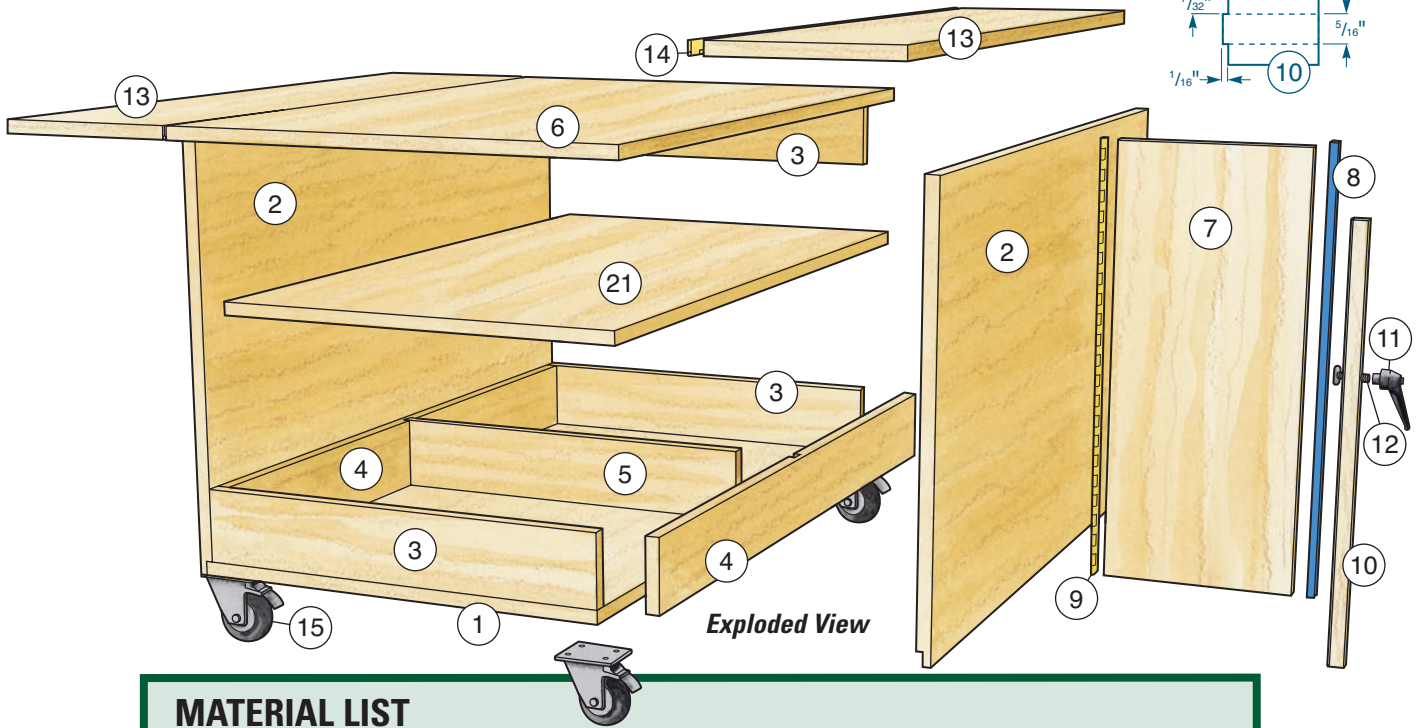
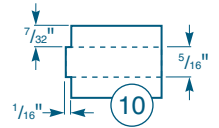

Exploded View

MATERIAL LIST

	T x W x L		T x W x L
1 Base (1)	3/4" x 23 3/4" x 40"	9 Support Hinges (2)	1 1/16" x 23 3/4" Continuous
2 Sides (2)	3/4" x 23 3/4" x 40"	10 Braces (2)	3/4" x 1" x 23 3/4"
3 Ends (3)	3/4" x 4" x 22 5/8"	11 Lever Knobs (2)	5/16"-18 Insert
4 Shelf Supports (2)	3/4" x 4" x 38 5/8"	12 T-bolts (2)	5/16" x 1 1/2"
5 Crosspiece (1)	3/4" x 4" x 21 1/8"	13 Wings (2)	3/4" x 10" x 40"
6 Top (1)	3/4" x 26" x 40"	14 Wing Hinges (2)	1 1/16" x 40 in. Continuous
7 Wing Supports (2)	3/4" x 9 5/8" x 23 3/4"	15 Casters (4)	3" Dia. Swivel/Lock
8 T-Track (2)	3/4" x 23 3/4"		

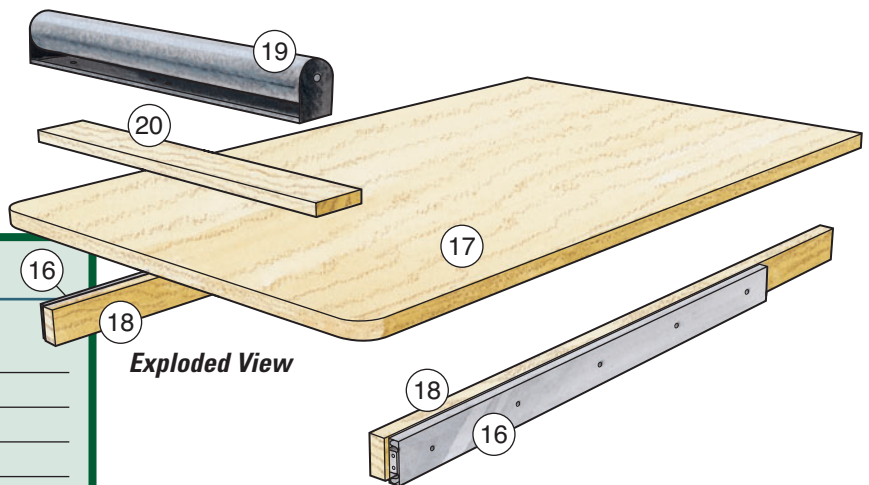

Exploded View

MATERIAL LIST

	T x W x L
16 Drawer Slides (2)	TopSlide 758 34"
17 Outfeed Table (1)	3/4" x 22½" x 37"
18 Table Cleats (2)	3/4" x 1¾" x 34"
19 Roller Assembly (1)	15¾" Roller
20 Roller Shim (1)	1/2" x 2¼" x 17"
21 Bottom Shelf (1)	3/4" x 22½" x 40"